

LAKWOOD INSTRUMENTS™
MODEL 1520/1530e

WATER TREATMENT SYSTEM
PH or ORP CONTROLLER

INSTALLATION & OPERATION MANUAL

SERIAL #: _____



Lakewood Instruments

7838 North Faulkner Road, Milwaukee, WI 53224 USA
Phone (800) 228-0839 • Fax (414) 355-3508
<http://www.lakewoodinstruments.com>

Lakewood Instruments™ Model 1520/30e Controller

Quick Installation Sheet

1. Install the controller on a flat, non-vibrating surface. Use the four (4) supplied mounting feet. Do not mount the controller to a steel object that has a large temperature change (side of cooling tower, etc). This can cause water to condense inside the enclosure.
2. Open the front cover keypad of the Model 1520/30e Controller by turning the two holding screws counter-clockwise.
3. Install water meters, chemical pumps, plumbing assemblies and the pH or ORP sensor. Configure Jumpers H1 and H2 for your sensor. (See drawings in back for instructions.)
4. Wire the flow switch (use jumper wire for no flow switch), pH or ORP sensor, water meters and 4-20 mA output/input, if applicable (see drawing on back). Ensure wiring connections are correct or damage may occur.
5. If doing a conduit installation, remove receptacles and wire pumps and bleed valve directly to the terminals. If using a motorized ball valve, wire as per wiring instructions. Refer to the instruction manual for more details.
6. Set the power selector switch to the appropriate voltage (115 or 230 VAC). For 230 VAC applications the power cord and receptacles must be removed.
7. Close the front cover keypad making sure both holding screws are tightened.
8. Plug in chemical pumps and bleed valve to controller (unless hardwired as per step #5).
9. Apply power to the 1520/30e controller, press "**CLR**" twice, press "**7**" System setup, press "**2**" Initialization, press "**2**" Whole controller, press "**1**" Yes. After initialization, press the "**CLR**" key several times until you get to the main menu.
10. Press "**1**" Process, Press "**ENT**". This screen allows manual control of the relay outputs to test the chemical pumps and bleed valve. Press "**CLR**" to return to the Process screen.
11. Press "**CLR**" to get to the main menu. Press "**7**" System Setup, press "**1**" Process Parameters, press "**1**" to set up the Damping. Press "**2**" Temp Compensation, select the temperature compensator for your sensor. Press "**3**" to set up the amount of temperature compensation. Press "**CLR**" several times to return to the main menu, press "**1**" for the Process screen.
12. To calibrate pH or ORP take a sample with a handheld pH or ORP meter, press the "**PRO**" button, press "**1**" for a single point calibration or press "**2**" for a two-point calibration, type in pH or ORP value, press "**ENT**".
13. Program the 1520/30e relays for bleed and chemical feed schemes. See instruction manual for more details.

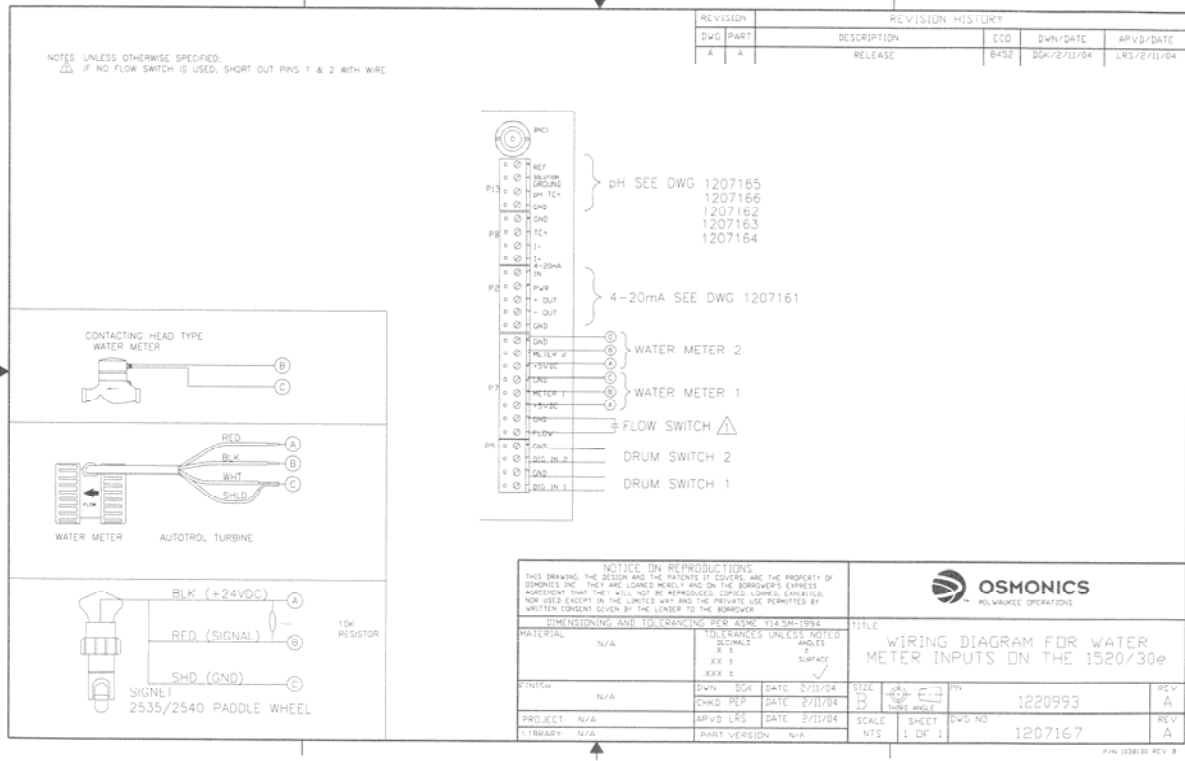
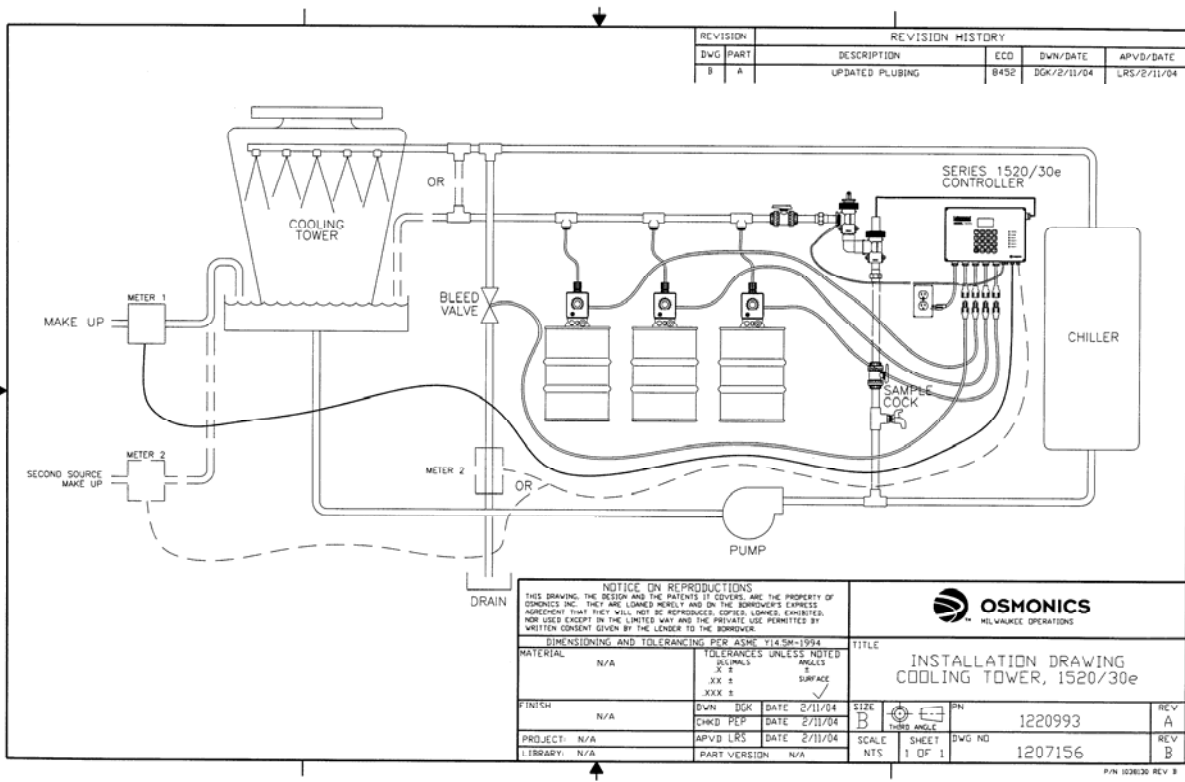

IMPORTANT NOTICE

WARNING: CHEMICAL FEED

All electromechanical devices are subject to failure from a variety of causes. These include mechanical stress, component degradation, electromagnetic fields, mishandling, improper setup, physical abuse, chemical abuse, improper installation, improper power feeds, and exposure.

While every precaution is taken to insure proper functioning, extra precautions should be taken to limit the ability of over-feeding by limiting chemical quantities available, secondary shut-downs, alarms, and redundancy or other available methods.

CAUTION: POWER SOURCE AND WIRING

Low voltage wiring and high voltage (110 plus) should not be run in the same conduit. Always run separately. Even shielded low voltage is not a guarantee of isolation.

Every precaution should be taken to insure proper grounding and elimination of shorting or Electromagnetic field (EMF) interference.

WARNING: ELECTRICAL SHOCK

To reduce the risk of electrical shock, this equipment has a grounding-type plug that has a third (grounding) pin. This plug will only fit into a grounding -type outlet. If the plug does not fit into the outlet, contact a qualified electrician to install the proper outlet. **DO NOT** change the plug in any way.

Lakewood Instruments

We thank you for your selection and purchase of a Lakewood Instruments product.

With proper care and maintenance, this device should give you many years of trouble-free service. Please take the time to read and understand this Installation and Operation Manual, paying special attention to the sections on **OPERATION** and **MAINTENANCE**.

If, in the future, any parts or repairs are required, we strongly recommend that only original replacement parts be used. Our Customer Service Department is happy to assist you with your parts or service requests.

 **Lakewood Instruments Customer Service and Technical Support Departments can be reached by calling (800) 228-0839 or faxing (414) 355-3508, Monday through Friday, 7:30 a.m. - 5:00 p.m. CST.**

 **Mail should be sent to:**

**Lakewood Instruments
7838 North Faulkner Road
Milwaukee, WI 53224 USA**

MODEL 1520/30e

Table of Contents

1.0 Introduction.....	7
2.0 Features, Benefits and Specifications.....	8
2.1 Features.....	8
2.2 Benefits.....	9
2.3 Specifications.....	9
2.4 Ordering Information.....	11
3.0 Unpacking, Mounting and Installation.....	12
3.1 Unpacking.....	12
3.2 Mounting the Enclosure.....	12
3.3 Plumbing Installation.....	13
3.3.1 Cooling Tower Plumbing.....	13
3.3.1.1 Blowdown Valve Sizing.....	14
3.3.2 Sensor Mounting.....	15
3.4 Electrical Installation.....	15
3.4.1 Incoming power.....	15
3.4.2 Relay Outputs.....	15
3.4.3 Flow Switch Wiring.....	16
3.4.4 Sensor Wiring.....	16
3.4.5 Sensor Jumper Configuration.....	17
3.4.6 Water Meters.....	17
3.4.7 Drum Switch Inputs.....	17
3.4.8 4-20 mA Output Wiring.....	18
3.4.9 4-20 mA Input Wiring.....	18
4.0 Functional Overview.....	19
4.1 Front Panel.....	19
4.2 Display.....	20
4.3 Keypad.....	20
4.4 Menu.....	20
4.5 Security Levels.....	21
5.0 Starting Up the Controller.....	21
6.0 Operation of Controller.....	22
6.1 Process Screen.....	22
6.2 Manual Operation of the Relays.....	23
6.3 Calibration of PH or ORP.....	24
6.4 Main Menu.....	25
6.5 Configuring the Relays.....	25
6.5.1 Configuring Relays 1-4.....	26
6.5.1.1 Disabled.....	26
6.5.1.2 By Setpoint.....	26
6.5.1.3 By Water Meter.....	27

6.5.1.4	By Percent of Time.....	28
6.5.1.5	By Feed Schedule.....	29
6.5.1.6	As an Alarm Relay.....	29
6.5.1.7	Configuring Relay 1 to Blowdown by Volume.....	30
6.5.2	Setting Up the Feed Schedule.....	31
6.5.3	Alarms.....	33
6.5.4	Water Meters.....	33
6.5.5	4-20 mA In/Out.....	34
6.5.5.1	Setup the 4-20 mA Output	35
6.5.5.2	Setup the 4-20 mA Input.....	36
6.5.6	The System Setup Menu.....	37
6.5.6.1	Process Parameters.....	37
6.5.6.1.1	Damping.....	37
6.5.6.1.2	Temperature Compensation.....	38
6.5.6.1.3	PH per °C.	38
6.5.6.2	Initialization.....	39
6.5.6.3	Change the Security Password.....	39
6.5.6.4	Firmware Version.....	40
6.5.6.5	Diagnostics.....	40
6.5.6.6	Setting the Controller Model.....	40
6.5.7	Setting the Clock.....	40
6.5.8	Changing the Security Levels.....	41
7.0	Maintenance.....	42
7.1	Sensor Maintenance.....	42
7.2	Flow Switch Maintenance.....	43
7.3	Replacing the Fuses.....	44
8.0	Troubleshooting.....	45
8.1	Error Messages.....	45
9.0	Factory Service.....	47
10.0	Drawings	
10.1	Cooling tower Suggested installation	
10.2	Chill loop / Cooling tower suggested installation	
10.3	pH jumper configuration	
10.4	ORP jumper configuration	
10.5	Wiring diagram for power connections	
10.6	Wiring diagram for water meter inputs	
10.7	Cooling tower sensor wiring pH	
10.8	Cooling tower sensor wiring ORP	
10.9	Process sensor wiring Model 520	
10.10	Process sensor wiring Model 530	
10.11	4-20 mA input and output wiring	

1.0 Introduction

The Model 1520/30e is a microprocessor based, menu driven, water treatment controller designed for use in cooling towers, process, and condensate systems. The Model 1520/30e provides for pH or ORP tracking and control, flow monitoring and chemical injection. The Model 1520/30e is NTL/CSA, and CE approved.

The Model 1520/30e uses the latest in microprocessor capability, giving the user a high level of application flexibility. A large illuminated graphics screen, multiple inputs, and an intuitive menu characterize this new technology.

Security features allow full access to programming features or restrict access to viewing only. An operator password can help ensure that only authorized personnel will operate the system.

The Model 1520/30e is user-friendly with a graphical screen, numeric keypad, LEDs for power, alarm and relay status. It accepts multiple inputs and is easily configured. It's a combination of reliability, accuracy, security and simplicity.

2.0 Features, Benefits, Specifications



Figure 1: Model 1520/30e

2.1 FEATURES

- Controller can be used for Cooling towers, Process, and Condensate systems.
- Removable power cord and receptacles for conduit installations. Enclosure is rated NEMA 4X
- Four user configurable relays for pH or ORP control and chemical addition. These relays can be configured in multiple ways including scheduled feed for biocide addition
- Two (2) water meter inputs, two drum switch inputs, pH or ORP input, flow switch input, 4-20 mA output and remote pH or ORP input via 4-20 mA are all standard features.
- Designed with a single circuit board for high reliability and lower cost.
- Large open shallow enclosure for easy wiring.
- Heavy-duty stainless steel domed numeric keypad and illuminated graphical display allow for quick and easy programming. Steel domed switches improve the tactile sensing and life expectancy of the keypad.
- The Model 1520/30e controller stores all setpoints, calibration values, and relay configurations in an EEPROM. An EEPROM does not require a battery to retain information, so if power is lost these values will be retained for years. The 1520/30e includes a capacitive backup device to retain information such as water meter totals, and clock and calendar information. The capacitive backup device will never need to be replaced and will hold data approximately 1 day after each power failure.

2.2 BENEFITS

- Easy to program, the Model 1520/30e Controller uses an intuitive menu and programs identical to the Lakewood 2000 Series controllers.
- Controller can be removed from a cooling tower and be placed in another type of application when used with the appropriate pH or ORP sensor and plumbing assembly.
- No add-on options. 4-20mA output, 4-20mA input, and scheduled feed features are standard.

2.3 Specifications

PH or ORP range

0-14 pH, -2000 to +2000 mV

PH or ORP sensor

Solution ground, Single ended, or Signal differential

PH or ORP Resolution

.01 pH
1 mV for ORP

Temperature comp.

Automatic

Accuracy & repeatability

± 1.0% of scale

Deadband/Setpoint

User programmable

Auto/Manual outputs

Menu selectable

Keypad

16 tactile steel-dome push buttons

Display

Illuminated 128 x 64 pixel LCD

Enclosure

NEMA 4x

Drum Switch Inputs

2 digital contact inputs

Water meter inputs (2)

Contact head, paddle wheel or turbine

Timer

Relay run time exceeded.

Input Signal

One 4-20 mA, non-isolated, internally powered Input.

Output Signal

One 4 – 20 mA, isolated or non-isolated optionally powered output for pH or ORP.

Output relays

4 selectable use

Relay ratings

3A each, 10A total

Power

120/240 VAC 50/60 Hz 6W

Ambient temp

32° - 140°F (0 - 60°C)

Storage temp

-4° - 150°F (-20 - 65°C)

Sensors/Plumbing	Cooling Tower	Process	Condensate
Max Pressure	140 psi (9.65 bar) @ 100°F	150 psi (10.3 bar)	70 psi (4.8 bar)
Max Temp	140°F (60°C)	230°F (110°C)	230°F (110°C)
Min flow	1 gpm (3.785 Lpm), 5 gpm max	Varies w/pipe size	1 gpm (3.785 Lpm)

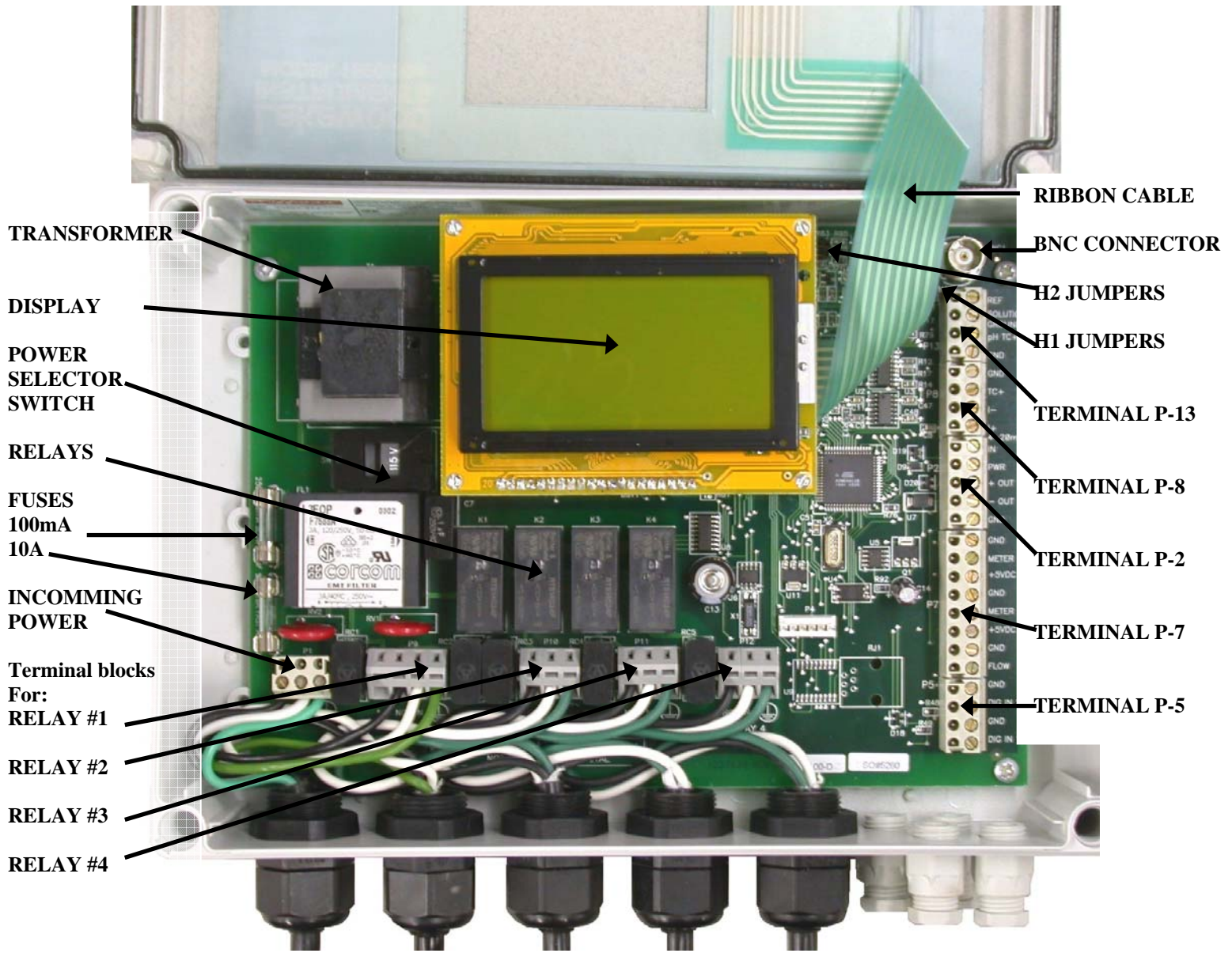

Figure 2: Model 1520/30e Enclosure

2.4 Ordering Information

CONTROLLER OPTIONS

1520/30e Water Treatment Controller. Universal pH or ORP controller is field programmable for cooling towers, process, and condensate applications.

Cooling Tower Options

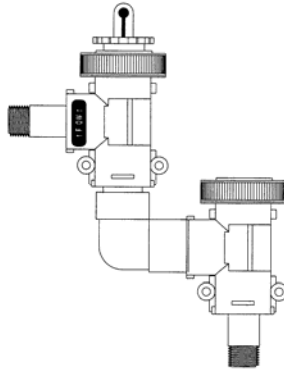

Cooling Tower Flow Switch Plumbing

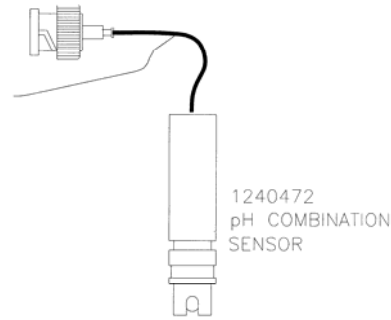

PH or ORP sensor

- 1240472 Cooling Tower pH Sensor with 15 ft of cable
- 1240473 Cooling Tower ORP Sensor with 15 ft of cable
- 1240477 Plumbing assembly with Flow Switch

Process / Wastewater Options

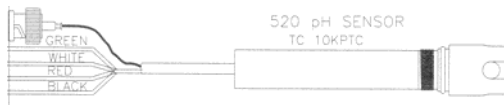

520 Series

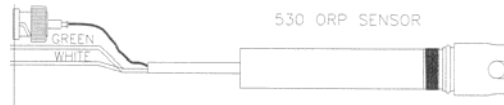

530 Series

Use the Lakewood Instruments 520 series sensors for pH.
Use the Lakewood Instruments 530 series sensors for ORP.

Condensate Options

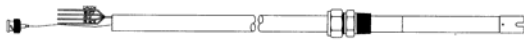

520-4-7I-10-STD

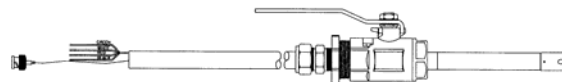

520-4-7R-18-STD

- 1165305520-4-7I-10-STD Condensate pH sensor with $\frac{3}{4}$ in NPT inline fitting.
- 1167983520-4-7R-18-STD Condensate pH sensor with 1.0 in NPT retractable inline fitting.

3.0 Unpacking, Mounting and Installation

3.1 Unpacking

Inspect the shipping carton for obvious external damage. Note on the carrier's bill-of-lading the extent of the damage, if any, and ***notify the carrier***. Save the shipping carton until your Model 1520/30e controller is started up.

☎ If shipping damage has occurred, call the Lakewood Instruments Customer Service Department at (800) 228-0839 and return the controller to the factory in the original carton.

3.2 Mounting the Enclosure

The Model 1520/30e can be mounted to a panel or to a flat non-vibrating wall. The Model 1520/30e includes four removable mounting feet that can be attached in the horizontal or vertical position. The mounting feet are attached to the enclosure using four screws.

To change the position of the mounting feet: remove the screws from the feet and reposition either vertically or horizontally as desired and reattach the screws.

The dimensions of the enclosure in inches are:

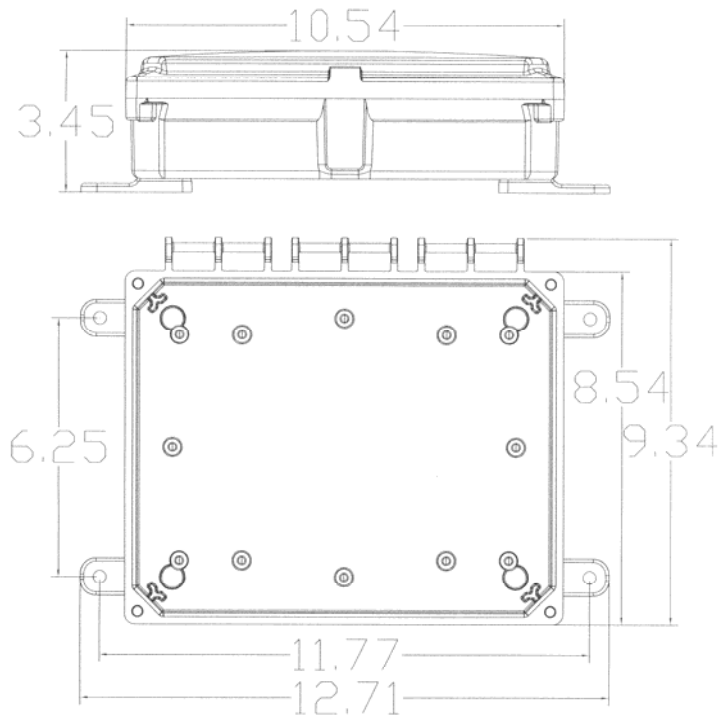

The model 1520/30e has a shipping weight of less than 5 lbs.

3.3 Plumbing Installation

3.3.1 Cooling Tower Plumbing

PLUMBING MATERIALS

- Inlet plumbing can be ¾ inch (1.9 cm) PVC, CPVC, or iron pipe.
- Provide at least 1 gpm (3.79 Lpm) to the sensor. A 4-psi (0.3 bar) differential pressure from take-off to injection is sufficient. If flow is marginal, consult your Lakewood Instruments Factory Representative. The maximum recommended flow is 5 gpm (18.93Lpm).
- Outlet plumbing can be ¾ inch (1.9 cm) PVC, CPVC, or iron pipe. PVC, CPVC Schedule 80 is recommended for strength and sunlight protection.
- If iron pipe is used, install a PVC union to relieve the stress on the plumbing.
- The sample line inlet should be plumbed downstream of the recirculating pump and upstream of the heat exchanger. This line brings the sample water into the sensor plumbing for pH or ORP measurement. If the Lakewood Instruments flow switch plumbing assembly is used, this flow of water also pushes the flow switch float up to activate the relay outputs of the controller.

NOTE: FOR YOUR CONVENIENCE, INCLUDE A LAKEWOOD INSTRUMENTS MODEL 9102 SAMPLE LINE SHUT-OFF VALVE AND A SAMPLE VALVE SPOUT (AS SHOWN) IN THE INLET FLOW PLUMBING.

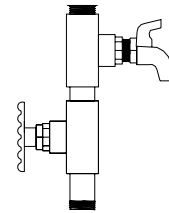

Figure 3:

Model 9102 Valve & Spout

- The sample line outlet flow (solution/sample line) should be plumbed to the tower return line or the tower basin, where you can insert your chemical feed system. Refer to the suggested installation drawing in the back of this manual for an example of a typical installation.
- Remember to install isolation and bypass valves so that maintenance can be performed.

WARNING: NEVER INJECT CHEMICALS UPSTREAM OF THE CONTROLLER FLOW CELLS!



If you have questions or need assistance, call Lakewood Instruments Technical Service Department at (800) 228-0839, Monday-Friday, 7:30 a.m. - 5:00 p.m. CST.

WARNING: SOME CHEMICALS MAY HAVE TO BE INJECTED DIRECTLY INTO THE COOLING SYSTEM WATER LINE AND NOT INTO THE SAMPLE LINE. CONTACT YOUR WATER TREATMENT SPECIALIST FOR SPECIFIC RECOMMENDATIONS.

NOTE: IF THE SOLUTION/SAMPLE LINE IS RETURNED TO THE COOLING TOWER RETURN LINE, USE A CORPORATION STOP (LAKEWOOD INSTRUMENTS MODEL 9160), A SOLUTION LINE INJECTOR OR A DISPERSING PIPE . THIS AIDS CHEMICAL-WATER MIXING AND ENHANCES WATER TREATMENT CONTROL CAPABILITIES.

3.3.1.1 Blowdown Valve Sizing

If you know your required blowdown flow and pressure range, you can use the chart below to determine the correct valve size. If not, consult your water treatment engineer.

Adjustable flow rate diaphragm valves require at least 10-psi (0.7 bar) differential pressure to close. If your water pressure is marginal, use a supply water pressure actuated diaphragm valve or a valve designed to work with zero differential pressure.

Extremely dirty cooling water will plug diaphragm valves. In such cases, use a motorized ball valve and a globe valve for flow control. A strainer ahead of the valve may be okay, but you must flush it regularly. If your flow lines are above 3 inch (for large systems), use a pneumatically operated butterfly valve.

- Be sure to provide isolation and bypass valves. Refer to drawings in the back of the manual for examples of typical installations. If your blowdown valve ever fails, you need to be able to bypass it in order to service it.

BLOWDOWN VALVE SIZING CHART					
Pressure range		Flow range		Suggested Valve Size	
(psi)	(bar)	(gpm)	(Lpm)	(inch)	(cm)
10-50	0.7-3.4	1-5	3.8-18.9	¾ inch	1.9 cm
50-150	3.4-10.3	5-10	18.9-37.9	¾ inch	1.9 cm
10-50	0.7-3.4	5-10	18.9-37.9	1 inch	2.5 cm
50-150	3.4-10.3	10-15	37.9-56.8	1 inch	2.5 cm
10-50	0.7-3.4	10-15	37.9-56.8	1½ inch	3.8 cm
50-150	3.4-10.3	15-20	56.8-75.7	1½ inch	3.8 cm
10-50	0.7-3.4	15-20	56.8-75.7	2 inch	5.1 cm
50-150	3.4-10.3	20-30	75.7-113.6	2 inch	5.1 cm
10-50	0.7-3.4	30-100	113.6-378.5	3 inch	7.6 cm
10-50	0.7-3.4	100-300	378.5-1135.5	4 inch	10.2 cm

3.3.2 Sensor Mounting

The pH or ORP sensor should be mounted in the vertical position. When using the plumbing with the Flow Switch, be sure that the flow sight is in the upright position. Avoid connections in “dead leg” sections of pipe. An air pocket around the electrode tip will cause erroneous readings. The sensor electrode should be in direct contact with the process flow.

3.4 Electrical Installation

3.4.1 Incoming Power 115/230 VAC

The Model 1520/30e can be powered from either 115 VAC or 230 VAC at 50/60 Hz. There is a power selector switch located in the upper left-hand corner of the control board. To select the appropriate voltage, simply slide the switch from one position to the other with a small screwdriver.

The Model 1520/30e controller comes with a power cord and female molded receptacles for the blowdown valve and chemical pumps. The power cord and receptacles are rated for 115VAC. If the controller will be powered by 230 VAC, the power cord and receptacles will need to be removed and the incoming power and the relay outputs will need to be hard-wired.

The incoming power is connected to terminal block P1 at the bottom left corner of the control board. There is a hot or line input (L1), a neutral input (N) and an earth ground input (⊕). Refer to the drawing in the back of this manual for wiring instructions.

3.4.2 Relay Outputs

The relay outputs are of the same voltage as the power input. Ensure that the devices that are to be connected to the relay outputs are of the same voltage rating or damage will occur.

The relay outputs are wired to the female molded receptacles. The molded receptacle on the far left is relay #1 and the molded receptacle on the far right is relay #4. If 115 VAC is used simply plug your devices into the molded receptacles. If 230 VAC is used, remove the receptacles and hard-wire your devices to the relay outputs.

Relay #1 has both a normally open and normally closed contact. This is designed for use with any device that requires either or both types of contacts for operation, such as a motorized blowdown valve. The normally open (NO) contact energizes when the relay turns on and the normally closed (NC) contact is energized when the relay turns off. The other three relays only have a normally open contact. Each relay output has a neutral (N) connection and an earth ground connection (⊕) connection.



To operate the terminal blocks to remove or add wiring, insert a small screwdriver into the slot above each wiring connection and pry upward while removing or inserting the wire.

Refer to the drawing in the back of this manual for wiring instructions.

3.4.3 Flow Switch Wiring

The model 1520/30e has a flow switch input. The purpose of the flow switch input is to disable the relay outputs on a loss of flow in the system. The flow switch input requires a digital contact. Any digital contact rated for 24 VDC and 500 mA may be used, such as a relay driven by the recirculating pump. Lakewood Instruments manufactures a flow switch plumbing assembly for use with the model 1520/30e in cooling water applications. The flow switch is wired to terminal block P7 terminals 1 and 2.

If a flow switch is not used then a jumper must be installed across the flow switch connections. Refer to the drawings in the back of this manual for wiring instructions.

3.4.4 Sensor Wiring

The model 1520/30e uses the Lakewood Instruments pH or ORP sensors. These sensors may be wired directly to the controller or to a 4-20 mA transmitter. The maximum recommended wiring distance for sensors without a 4-20 mA transmitter is 15 feet.

Direct-wired sensors are wired directly to the P13 terminal block and BNC1 on the upper right corner of the control board. Refer to the drawing in the back of this manual for wiring instructions for each of the available Lakewood Instruments pH or ORP sensors.

4-20 mA transmitters are wired to terminal block P2. The model 1520/30e controller powers this 4-20 mA device. Refer to the drawing in the back of this manual for wiring instructions for the 4-20 mA input.

3.4.5 Sensor Jumper Configuration

The model 1520/30e controller uses jumper blocks to configure the sensor input for pH or ORP. Jumper blocks H1 and H2 must be configured for proper operation of the sensor input. Refer to drawing 1207168 for ORP configuration and 1207169 for pH configuration.

Part # or Model #	Sensor Type
1167155	Differential / Reference on Shield
1169065	Single-Ended / Reference on Shield
1240472	Differential / Reference on Shield
1240473	Single-Ended / Reference on Shield
520 Series	Differential / Reference on Wire
521 Series	Differential / Reference on Shield
530 Series	Single-Ended / Reference on Wire

3.4.6 Water Meters

The Model 1520/30e will accept two water meter inputs. These inputs can be configured for make-up, make-up Second Source, Bleed, or Chill Loop make-up. Refer to the water meter manufacturer's manual for plumbing information.

The 1520/30e series controllers will work directly with the following types of meters: dry contacting head meters, Seametrics open collector output meters, Signet 2535 and 2540 paddle wheel meters, and the Autotrol 1 inch and 2 inch meters. Contact Lakewood Instruments for other types of water meters. The water meters are wired to terminal block P7 on the right-hand side of the control board. Refer to the drawing in the back of this manual for wiring instructions.

3.4.7 Drum Switch Inputs

The model 1520/30e will accept two drum switch inputs. The drum switches are wired to terminal block P5. The drum switch input requires a digital contact. Any digital contact rated for 24 VDC and 500 mA may be used. Refer to the drawing in the back of this manual for wiring instructions.

3.4.8 4-20 mA Output Wiring

The model 1520/30e has one 4-20 mA output for pH or ORP. This output can be isolated or non-isolated, externally powered or internally powered. If the 4-20 mA output is internally powered then it is non-isolated. If the 4-20 mA output is externally powered then it is isolated.

The 4-20 mA output is wired to terminal block P2 on the right-hand side of the control board. Refer to the drawing in the back of this manual for wiring instructions.

3.4.9 4-20 mA Input Wiring

The model 1520/30e can accept a 4-20 mA input as the pH or ORP input. The pH or ORP sensor is wired to a 4-20 device and the device is wired to terminal block P2 on the right-hand side of the control board. This input is a non-isolated input and the controller powers it. Refer to the manufacturer instructions for wiring of the sensor to the 4-20 mA input device.

Refer to the drawing in the back of this manual for wiring instructions.

4.0 Functional Overview

4.1 Front Panel

Figure 4: Model 1520/30e Front Panel with Display



4.2 Display

The model 1520/30e uses an illuminated 128x64-pixel LCD digital display for ease of viewing. It has multiple lines to display information such as the pH or ORP reading, alarms, relay status, relay configuration, clock, flow rates and total flow for both water meters, and menu selections.

4.3 Keypad

The model 1520/30e uses a 16-key steel-domed numeric keypad for ease of programming. The keys have the following functions:

ENT	To accept a setting or to enter a screen.
CLR	To exit a screen or to access the main menu.
PRO	To calibrate the controller.
DSP	Same as CLR.
UP arrow	To move about in the menu.
DOWN arrow	To move about in the menu.
Number keys	To input a value or to select a menu item.

4.4 Menu

The model 1520/30e is programmed and calibrated by the use of a menu. The complete **Main Menu** has 8 available options that can be accessed in the **Technician Level**. However, only six options can be viewed on the display at one time. Use the **↑** and **↓** keys to scroll through the options. As an introduction, here is a graphic overview of the first level of each option in the **Main Menu** to see how it operates. Complete details of each option are provided later in this manual.

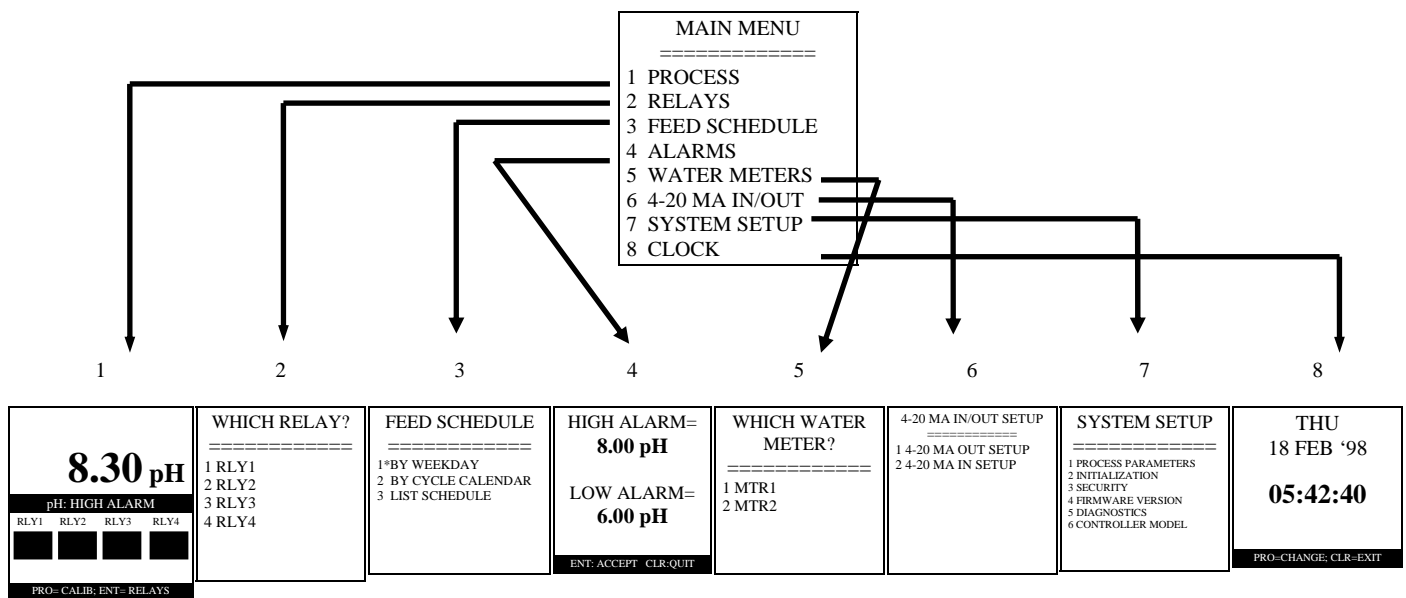

4.5 Security Levels

The model 1520/30e has a security level to prevent tampering of the controller. This security level is called View Only. When the controller is in the View Only security level, the menu is locked out and changes to the settings are not allowed.

The security level is password protected. The default password is 2222. If the controller is in the view only security level just press 2222 on the keypad to access the menu. This password can be changed in the main menu. If the password has been changed, input the new password in place of the “2222” above to unlock the menu.

5.0 Starting Up the Controller

Once the Installation is complete it is time to start up the controller.

Initiate sample flow to the controller by opening the sample line isolation valves. Check for leakage.

Power up the controller by turning on the circuit breaker or plugging the power cord into a 120 VAC receptacle.

It is best to initialize the whole controller to remove any settings that may be in the memory before programming the controller. Refer to section 6.5.6.2 of this manual to initialize the controller.

Configure the controller for the appropriate model; 1520 for pH or 1530 for ORP. Refer to section 6.5.6.6.

If the pH or ORP input will be coming from a 4-20 mA device enable the 4-20 mA input by following section 6.5.5.2.

If pH or ORP is not coming from a 4-20 mA device set up the temperature compensation for the sensor. Follow section 6.5.6.1.2.

Set the clock by following section 6.5.7.

Set the high and low pH or ORP alarms by following section 6.5.3.

Configure the relays for operation by following section 6.5.

Calibrate the pH or ORP by following section 6.3.

Verify operation of the controller before leaving the area.

6.0 Operation of the Controller

6.1 Process Screen

The screens that are used the most in the 1520/30e controller are the Process Screens. Below are the process screen views. The process screen has three sections. The top section shows the pH or ORP reading. The alarm bar is the middle section and appears between the top and bottom sections. It is solid in appearance and flashes showing the current active alarms in sequence if there are multiple alarms. The bottom section has user selectable readings as shown below.

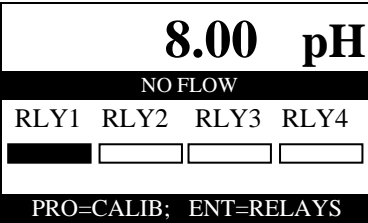
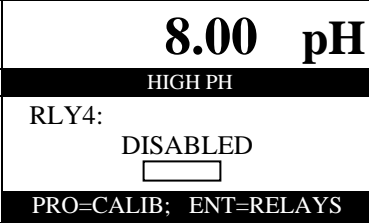
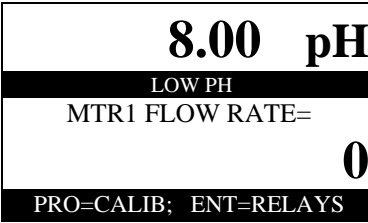
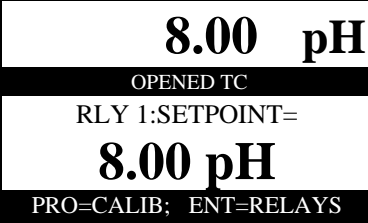
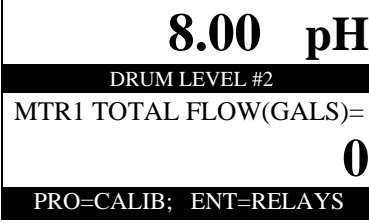
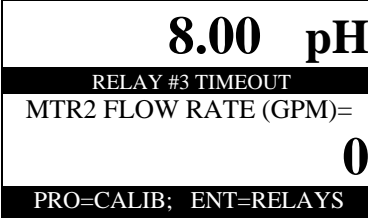
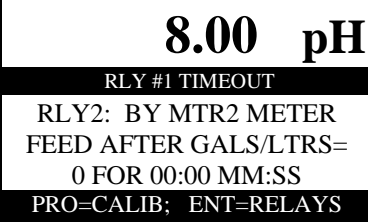
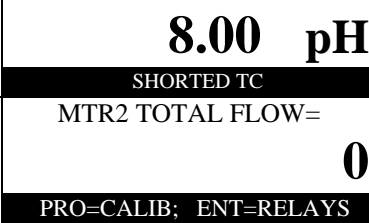
1 - DATE SCREEN 			<ul style="list-style-type: none"> • There are many different screens available in the PROCESS screen. These screens allow you to view the units settings (incl. time setting, relay set-ups, flow rates, total flow, etc.) without the danger of altering them. Access these screens by using the ↑ and ↓ keys to scroll through the available screens. • Press “ENT” to manually enable a relay for testing or troubleshooting purposes. • Press “PRO” to calibrate the pH or ORP.
2 - ALL RELAY SCREEN 	5 - RELAY 2,3,4 SETTINGS 	8 - MTR1 FLOW RATE 	
3 - BLOW SETPOINT SCREEN 	6 - MTR1 TOTAL FLOW 	9 - MTR2 FLOW RATE 	
4 - RELAY 2 SETTINGS 	7 - MTR2 TOTAL FLOW 		

6.2 Manual Operation of the Relays

All four of the relays can be operated manually. To manually operate the relays:

Go to the **Process** screen. Press “**ENT**”. You will be taken to a screen that looks like:

AUTO-MANUAL (5 MINS.)	
(1) RLY1	<input checked="" type="checkbox"/>
(2) RLY2	<input type="checkbox"/>
(3) RLY3	<input type="checkbox"/>
(4) RLY4	<input type="checkbox"/>
Press 1-4; CLR=EXIT	

Press “**1-4** “ to manually change the state of a particular relay. If the relay is already on, pressing that number will turn it off. A five-minute countdown timer will start. After five minutes has expired the relay will return to automatic control. A relay that is in manual control will stay in manual control until the five minutes expires even if this screen is exited. The five-minute timer helps to prevent damage to the system if a relay is left in manual. **WARNING: Manual control overrides everything including the flow switch lockout. Use care when operating relays manually with no flow in the system.**

6.3 Calibration of PH or ORP

The pH or ORP requires periodic calibration. Calibration is usually required after cleaning the sensor.

A single point calibration should always be performed with the sensor in the piping assembly with good flow past the sensor. It is necessary to have an accurate reading of the system water to properly calibrate the controller. A hand-held pH or ORP meter that tests the sample works well for this purpose.

If the pH or ORP sensor is connected to a 4-20 mA device, follow the manufacturer instructions for calibrating that device.

If the pH or ORP sensor is directly wired to the 1520/30e controller follow these instructions for calibration.

- Ensure that the controller is operating with good flow past the sensor.
- Take a sample of the water and measure with a hand-held pH or ORP tester.
- From the **PROCESS** screen, press “**PRO**” to enter the calibration screen.

CALIBRATION
=====
1 SINGLE POINT
2 TWO POINT

For a Single Point Calibration

- Press “1” **SINGLE POINT**
- Use the keypad to input the pH or ORP reading from the hand-held. Press “ENT”.
- The controller will respond with “**CALIBRATION COMPLETE**”.
- Take another hand-held sample to verify calibration.

ONE POINT CALIBRATION
08.04 pH
ENT=ACCEPT; CLR=QUIT

For a Two Point Calibration

- For a two point calibration, two separate buffer solutions at least two pH units apart are required.
- Press “2” **TWO POINT**.
- Place the sensor and solution ground wire, if required, in the first buffer solution, allow the reading to stabilize.
- Use the keypad to input the pH or ORP value of the first buffer. Press “ENT”.
- Place the sensor and solution ground wire, if required, in the second buffer solution, allow the reading to stabilize.
- Use the keypad to input the pH or ORP value of the second buffer. Press “ENT”.
- Return the sensor to the system and reattach the solution ground wire, if required.
- Check the calibration vs. actual and perform a single point calibration if required.

FIRST POINT OF TWO
04.00 pH
ENT=ACCEPT; CLR=QUIT

A two point calibration is not required for proper operation of the controller. There is a factory default two point calibration in the programming.

Calibration Errors.

The controller will **not** be able to complete a calibration if any of the following alarms are present: **Opened T.C., Shorted T.C., High Reference Impedance, or Open P.T. Band.**

In addition, the following errors may be received during the calibrations:

Deviation > 1.5 pH from default / Deviation >300 mV from default This means that the input to the controller does not agree with the value that is being inputted by at least 1.5 pH units for pH or 300 mV for ORP. The most common cause of this error is a bad or dirty sensor.

Calibration Points Less Than 2 pH Apart / Calibration Points less than 200 mV Apart. The two buffer solutions used during a two point calibration must be at least two pH units apart for pH or 200 mV apart for ORP for a good calibration.

6.4 Main Menu

The **MAIN MENU** of the 1520/30e looks like this:

```
          MAIN MENU
          =====
1 PROCESS
2 RELAYS
3 FEED SCHEDULE
4 ALARMS
5 WATER METERS
6 4-20 MA IN/OUT
7 SYSTEM SETUP
8 CLOCK
```

The **MAIN MENU** can be accessed from the **PROCESS** screen by pressing “**CLR**”. If “**CLR**” is pressed and the **MAIN MENU** does not appear, the controller is probably in the **VIEW ONLY** security mode. If the controller is in the **VIEW ONLY** security mode, enter the security password to be able to access the **MAIN MENU**.

To move about in the menu screen use the **↑** and **↓** keys to highlight the desired option and press “**ENT**” or simply press the number key for the desired option.

Use the “**ENT**” key to accept a setting or to enter a screen. Use the “**CLR**” key to reject a setting or to exit a screen. From anywhere in the menu, pressing “**CLR**” will take you one step closer to the **MAIN MENU**.

Each of the **MAIN MENU** options are discussed in detail later in this manual.

6.5 Configuring the Relays

To access the relay configuration screen from the **MAIN MENU**, press “**2**” or highlight **RELAYS** and press “**ENT**”. The following screen will appear.

```
          WHICH RELAY?
          =====
1 RLY1
2 RLY2
3 RLY3
4 RLY4
```

Select the relay that you want to program.

6.5.1 Configuring Relays 1-4

All four relays can be configured to operate based on: Disabled, Setpoint, Water Meter, Percent of Time, Feed Schedule, or by Alarm. In addition to the above, Relay #1 can be configured to Blowdown by Volume. When a relay is selected for programming the following screen will appear. This is the **RELAY OPTIONS** screen. The asterisk (*) next to one of the options tells you how that relay is configured to feed.

```
RELAY OPTIONS
=====
1*DISABLED
2 SETPOINT
3 WATER METER
4 PERCENT OF TIME
5 FEED SCHEDULE
6 ALARM RELAY
7 BLOWDOWN BY VOLUME
```

NOTE: ITEM 7 WILL ONLY APPEAR IN THE RELAY OPTIONS SCREEN FOR RELAY #1.

6.5.1.1 Disabled

Relay #1 can be disabled. When a relay is disabled, it will not energize.

- From the **RELAY OPTIONS** screen press “1” **Disabled** to disable the relay.

6.5.1.2 Based On Setpoint

To set up a relay to operate based on a setpoint:

- Press or select “2” **SETPOINT**. The following screen will appear.

```
BASED ON SETPOINT
=====
1 SETPOINT VALUES
2 WHEN TO FEED
```

SETPOINT

In the **SETPOINT VALUES** screen you will set the **SETPOINT**, the **DEADBAND** and the amount of time for the **TIMEOUT** alarm.

The **SETPOINT** is the pH or ORP value that you are trying to maintain. Check with your water treatment engineer to determine the pH or ORP setpoint for your system needs.

Follow these instructions to establish the controller's setpoint:

- Press “1” or highlight **SETPOINT VALUES** and press “ENT”.
- Use the keypad numbers to enter the proper pH or ORP setpoint and press “ENT”. When finished, you will automatically be prompted to set the deadband.

DEADBAND

After the setpoint is established, the controller's deadband must also be set. "**Deadband**" refers to the amount of pH or ORP above and below the setpoint—a range within which the controller will not react. Due to continuous fluctuations in the pH or ORP level, it is necessary to have this deadband range or stable readings will be difficult to obtain. The Deadband should be a small percentage of the setpoint. Half the deadband amount will be automatically put above the setpoint, and the other half below it.

For example, a pH setpoint of 7.50 pH with a deadband of 0.20 pH would result in the relay turning on at 7.60 pH and turning off at 7.40 pH.

- Use the keypad numbers to enter the proper deadband setpoint and press "**ENT**". When finished, you will automatically be switched to the **TIMEOUT** alarm screen.

TIMEOUT

The **TIMEOUT** alarm is designed to notify the operator of a problem in the system such as a failed pump, an empty chemical drum, or a problem with the controller. The relay timeout function is an alarm feature that is displayed on the 1520/30e series display process screen and **it will turn off the pump**. If a relay is configured as an alarm relay, the **TIMEOUT** alarm will energize the alarm relay. To disable this function, simply program 0 hours, 0 minutes.

- Use the keypad numbers to enter the time in hours and minutes before this alarm will appear and press "**ENT**".

WHEN TO FEED

The relay can be configured to operate either **above the setpoint** or **below the setpoint**. When the relay is configured to operate **above the setpoint**, the relay will turn on when the pH or ORP rise above the setpoint plus one-half of the deadband. When configured to operate **below the setpoint**, the relay will turn on when the pH or ORP falls below the setpoint minus one-half of the deadband.

- In the **WHEN TO FEED** screen, select either "**1**" **ABOVE SETPOINT** or "**2**" **BELOW SETPOINT**.

6.5.1.3 By Water Meter

All four relays can be configured to operate for a specified amount of time based on a specified amount of flow through the water meter inputs. MTR1, MTR2 or the sum of BOTH water meter inputs can activate the relay.

- From the **RELAY OPTIONS** screen press "**3**" **WATER METER**.
- Select either **MTR1** or **MTR2** or **BOTH** as the trigger for the relay.
- Use the keypad to enter the amount of flow before the relay is activated. Press "**ENT**".
- Enter the amount of time that the relay will be activated. This time is in minutes and seconds. Press "**ENT**".

6.5.1.4 By Percent of Time

The Percent of Time feature allows you to feed chemical strictly based by a percent of time. This relay control scheme works in patterns of 20-second time blocks. A relay is on for some multiple of 20 seconds and off for some multiple of 20 seconds. Below is a chart showing how Percent of Time works over a 400 second example.

x = 20 seconds on
 - = 20 seconds off

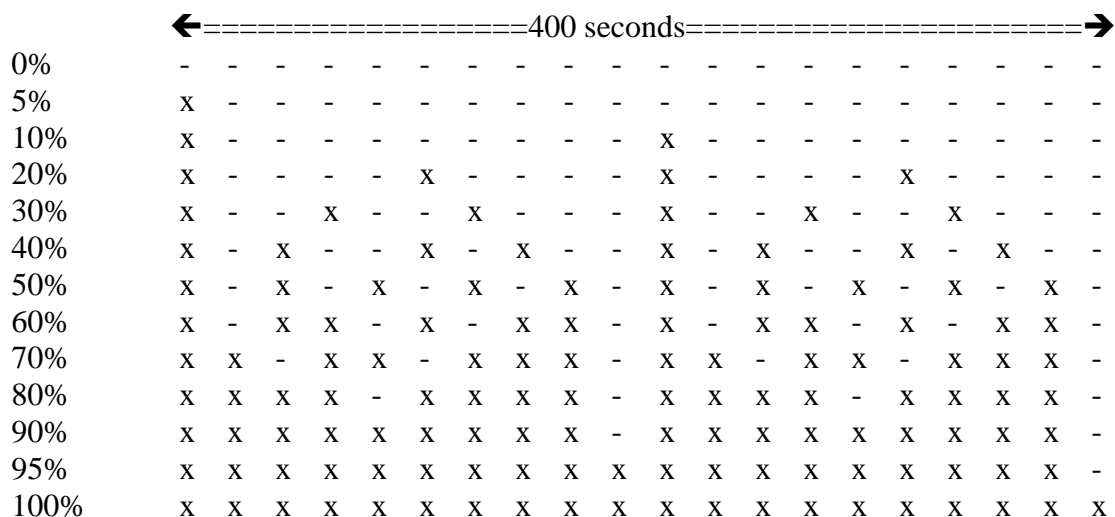

A 400-second example is shown because it will cover the patterns of the major percentages. The patterns for odd values such as 37% or 52% cannot be shown in a 400-second time interval but they would look very much like those patterns shown for 40% and 50% respectively. In an extreme case such as 99%, the relay would be on for 99 20-second blocks (1980 seconds) and then off for 1 20-second block (20 seconds) and then on for 1980 seconds and off for 20 seconds etc.

To determine the total amount of chemical fed over a 24 hour period, multiply the percent of time by the number of hours a day that your controller is operating, then multiply by your chemical pump flow rate per hour.

For example:

We select 10% of the time, our controller operates 24 hours a day and our chemical pump flow rate is 1 gallon per hour.

$$10\% \times \frac{24 \text{ hours}}{\text{Day}} \times \frac{1 \text{ gallon}}{\text{Hour}} = \frac{2.4 \text{ Gallons}}{\text{Day}}$$

- From the **RELAY OPTIONS** screen press "4" **PERCENT OF TIME**.
- Use the keypad to enter the percentage of time desired. Press "ENT".

6.5.1.5 By Feed Schedule

The feed schedule is used to feed chemicals such as biocides on a time of day basis. Setting up the feed schedule is a two-part process. The first part is to configure the relay so that it will operate by feed schedule. The second part of the process is to configure the feed schedule. The feed schedule is covered in section 6.5.2.

- From the **RELAY OPTIONS** screen press "6" **FEED SCHEDULE**.

The controller will respond with the following screen.



The relay has been configured to operate based on a feed schedule but the relay will not activate because the feed schedule has not been programmed yet.

6.5.1.6 As an Alarm Relay

All four relays can be configured as alarm relays. Any alarm will cause the relay to activate. These alarms include: HIGH PH or ORP, LOW PH or ORP, OPENED TC, SHORTED TC, DRUM LEVEL #1, DRUM LEVEL #2, RELAY #1 TIMEOUT, RELAY #2 TIMEOUT, RELAY #3 TIMEOUT, RELAY #4 TIMEOUT, and the NO FLOW alarm.

- From the **RELAY OPTIONS** screen press "7" **ALARM RELAY**. The controller will respond with the following screen.



NOTE: A relay that is configured as an alarm relay will be activated any time any alarm including the "NO FLOW" alarm is present.

6.5.1.7 Blowdown by Volume

Relay #1 can be configured to Blowdown based on Volume. When configured based on volume, the relay will turn on after a specified amount of makeup volume occurs and will turn off after a specified amount of blowdown is met. This relay configuration requires two water meters and the use of both water meter inputs one for makeup and one for blowdown.

To program RELAY #1 for **BLOWDOWN by VOLUME**,

- Select "7" **BLOWDOWN BY VOLUME** in the RELAY #1 **RELAY OPTIONS** screen. The following screen will appear.

MAKEUP WATER METER? =====
1*MTR1
2 MTR2

- Select the meter to which your makeup meter is wired and press "ENT". The controller automatically uses the other water meter input as the blowdown water meter.
- Use the keypad to enter the volume of makeup after which you want to blowdown then press "ENT"
- Input the amount of blowdown that you want to blow down then press "ENT".
- The next screen is the **EXCESS BLOWDOWN TIME ALARM** screen. This alarm occurs if the specified amount of blowdown is not reached within the specified amount of time for this alarm. Enter the amount of blowdown time before the **EXCESS BLOWDOWN TIME ALARM** will occur then press "ENT". **This alarm will close the blowdown valve** and it will give an alarm indication on the display. The alarm time is set in hours and minutes. To disable this feature, enter "00:00".
- The relay will activate again when the specified amount of makeup volume is achieved even though the **EXCESS BLOWDOWN TIME ALARM** has occurred, however, **the alarm will still be present until the specified blowdown volume is reached.** This will provide the operator with an indication that there is a problem with the blowdown system.

6.5.2 Setting up the Feed Schedule

Refer to section 6.5.1.5 to configure a relay to feed based on the feed schedule before continuing with this section.

To get to the feed schedule menu:

- From the **MAIN MENU** press **"3"** **FEED SCHEDULE**. You will see the following screen:

```
FEED SCHEDULE
=====
1*BY WEEKDAY
2 BY CYCLE CALENDAR
3 LIST SCHEDULE
```

The feed schedule can be programmed to feed chemicals by either **WEEKDAY** or by a **CYCLE CALENDAR** basis. **NOTE:** All scheduled feeds will be by the method selected.

BY WEEKDAY is used to feed chemicals by the weekday name, i.e. Monday, Tuesday, Wednesday etc.. This is a seven-day schedule. At the end of the week, the schedule starts over again. To configure the feed schedule to feed by weekday:

- From the **FEED SCHEDULE** screen, press **"1"** **BY WEEKDAY**.

BY CYCLE CALENDAR is used to feed chemicals by a schedule other than one that is seven days long. **BY CYCLE CALENDAR** can be used to feed the same chemical every day or up to 28 days between feedings. The operator specifies the number of days in the cycle calendar. After the cycle calendar is completed, the schedule starts over again. This method of feeding is particularly useful when feeding two biocides on an alternating weekly basis. To configure the feed schedule to feed by cycle calendar:

- From the **FEED SCHEDULE** screen, press **"2"** **BY CYCLE CALENDAR**.
- Use the keypad to enter the number of days in your cycle then press **"ENT"**. Remember the maximum number of days allowed is 28.
- Use the keypad to enter which day today is in your cycle; e.g. today is day number 5 in my 14-day cycle. Then press **"ENT"**.

After selecting whether the feed schedule will be fed by **WEEKDAY** or by **CYCLE CALENDAR** it is time to actually program the feed schedule. To enter the actual feed schedule or to edit the feed schedule from the feed schedule screen above:

- Press **"3"** **LIST SCHEDULE**. This will take you to a list of all scheduled feeds as shown in the screen on the next page.

NOTE: A maximum of 12 scheduled feeds may be programmed into the controller.

FEED SCHEDULE			
=====			
1	01	03:00	RLY2
2	00	00:00	
3	00	00:00	
4	00	00:00	
5	00	00:00	
6	00	00:00	

- If there are no scheduled feeds, select the first schedule and press "ENT". If you are editing the schedule, select the schedule that you want to edit and press "ENT".

Below is an example screen for programming a chemical feed. Before programming a chemical feed, you need to configure the relay to be a feed schedule relay as per section 6.5.1.5.

RELAY (ARROWS): NONE
CYCLE DAY : 0
START TIME : 00:00
FEED DURATION : 00:00
LOCKOUT TIME : 00:00
<UP><DOWN>ENT: ACCEPT

- To program the schedule use the keypad to enter the values in the above screen. Press "ENT" to move to the next item.

RELAY is which relay you want to program (you must configure a relay to be a feed schedule relay first). Use the arrow keys to select the available relays.

CYCLE DAY or DAY is the day you wish to actuate the feed schedule relay.

START TIME is the time of day you want to start the feed schedule sequence. This time is based on a 24 hour clock; i.e. 10p.m is 22:00.

FEED DURATION is the amount of time the feed schedule relay will be on.

LOCKOUT TIME after the feed schedule relay is done, an additional lockout time for relays **1, 2, 3,** and **4** can be programmed. The lockout time prevents the other relays from operating until this time expires. Setting this time to **0:00** will disable this feature.

NOTE: All Times are in Hours and Minutes

6.5.3 Alarms

The Model 1520/30e is equipped with both high and low pH or ORP alarms. This menu option allows you to program the specific values for these alarms. When a pH or ORP alarm is received, it will appear as a flashing message in the middle of the display and any configured alarm relays will be activated. Consult your water treatment specialist when determining the proper High and Low Alarm values for your system.

To get to the alarm settings:

- From the **MAIN MENU** press "4" **ALARMS**. Use the keypad to enter a value for the high alarm. Press "ENT".
- Use the keypad to enter a value for the low alarm and press "ENT".

HIGH ALARM= 10.00 pH
LOW ALARM= 4.00 pH
ENT: ACCEPT CLR:QUIT

6.5.4 Water Meters

The 1520/30e series controllers will work directly with the following types of meters: dry contacting head meters, Seametrics open collector output meters, Signet 2535 and 2540 paddle wheel meters, and the Autotrol 1 inch and 2 inch meters. Contact Lakewood Instruments for other types of water meters.

Both water meter inputs are programmed in the same manner.

To get to the water meter configuration screen:

- From the **main menu**, press "5" **WATER METERS**. This will take you to the **WHICH WATER METER SCREEN**.
- Press "1" for **MTR1** or press "2" for **MTR2**.
- The water meters can be configured for gallons or liters. Press "1" for **GALLONS** or press "2" for **LITERS**.
- This will take you to the **WATER METER TYPES** screen as shown below.

WATER METER TYPES	
=====	
1	CONTACTING HEAD
2	PADDLE WHEEL
3	AUTOTROL TURB 1 IN.
4	AUTOTROL TURB 2 IN.

- Use the keypad to select the type of water meter that you are using.

If **CONTACTING HEAD** is selected:

- You will be taken to the **GALLONS OR LITERS PER CONTACT** screen. Use the keypad to enter the number of gallons or liters per contact for your specific meter then press "ENT". You will then be asked if you want to reset the total count for that meter to zero. Press "1" for **YES** or press "2" for **NO**.

If **PADDLE WHEEL** is selected:

- You will be taken to the **K-FACTOR** screen. Use the keypad to enter the K-factor for your particular water meter then press "ENT". You will then be asked if you want to reset the total count for that meter to zero. Press "1" for **YES** or press "2" for **NO**.

If **AUTOTROL TURB 1 IN.** is selected:

- The controller will confirm that the **AUTOTROL TURB 1 IN.** has been selected and you will be asked if you want to reset the total count for that meter to zero. Press "1" for **YES** or press "2" for **NO**.

If the **AUTOTROL TURB 2 IN.** is selected:

- The controller will confirm that the **AUTOTROL TURB 2 IN.** has been selected and you will be asked if you want to reset the total count for that meter to zero. Press "1" for **YES** or press "2" for **NO**.

6.5.5 4-20 mA IN/OUT

The model 1520/30e has one 4-20 mA output that is configured for pH or ORP.

The model 1520/30e has a 4-20 mA input that is used for a remote pH or ORP input to the controller.

6.5.5.1 Set Up of the 4-20 mA Output

To set up the 4-20 mA output:

- From the **Main Menu**, press "6" **4-20 mA IN/OUT**.
- Press "1" **4-20 mA OUT SETUP**.

There are three things that can be done from the **4-20 mA Out Setup** screen; set the 4-20 mA range, take manual control of the 4-20 mA output and calibrate the 4-20 mA output. Below is the **4-20 mA Setup** screen.

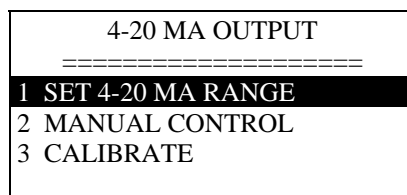

Set the 4-20 mA Range

The 4-20 mA output range must be set for the output to be useful.

- From the **4-20 mA Setup** screen, press "1" **Set the 4-20 mA RANGE**.
- Use the keypad to enter a pH or ORP value for the 4-mA point. Press "ENT".
- Use the keypad to enter a pH or ORP value for the 20-mA point. Press "ENT".

Manual Control

Manual control is used to temporarily change the 4-20 mA output.

- From the **4-20 mA Setup** screen, press "2" **MANUAL CONTROL**.
- Use the up and down arrow keys to raise or lower the 4-20 mA output. To exit this screen and restore automatic control of the 4-20 mA output press "CLR".

Calibrate

The 4-20 mA needs to be calibrated to the actual output to be accurate. A milliamp meter is necessary to calibrate the 4-20 mA output. Connect the milliamp meter in-line with one leg of the 4-20 mA output. Refer to the drawing in the back of this manual for wiring instructions.

- From the **4-20 mA Setup** screen, press "3" **CALIBRATE**.
- Use the keypad to enter the milliamp reading from the milliamp meter for the **4-mA** point. Press "ENT".
- Use the keypad to enter the milliamp reading from the milliamp meter for the **20-mA** point. Press "ENT".

6.5.5.2 Set Up of the 4-20 mA Input

The 4-20 mA input is used for a remote pH or ORP application where the pH or ORP sensor will be mounted greater than 15 feet from the controller. An external 4-20 mA device is required.

To set up the 4-20 mA input:

- From the Main Menu press "6" **4-20 mA IN/OUT**.
- Press "2" **4-20 mA IN SETUP**.

There are three things that can be done from the **4-20 mA IN Setup** screen; set the 4-20 mA range, enable or disable the 4-20 mA input and calibrate the 4-20 mA input. Below is the **4-20 mA INPUT** setup screen.

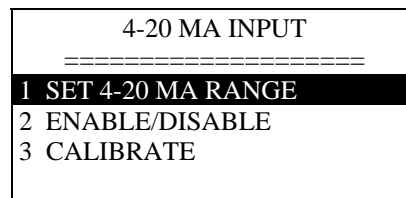

Set the 4-20 mA Range

The 4-20 mA input range must be set to the same range as the 4-20 mA input device to be useful.

- From the **4-20 mA IN** setup screen, press "1" **Set 4-20 mA RANGE**.
- Use the keypad to enter a pH or ORP value for the 4-mA point. Press "ENT".
- Use the keypad to enter a pH or ORP value for the 20-mA point. Press "ENT".

Enable/disable

To use the 4-20 mA input, it must be enabled.

- From the **4-20 mA IN** setup screen, press "2" **ENABLE/DISABLE**.
- Press "1" to enable the 4-20 mA input or press "2" to disable the 4-20 mA input.

Calibrate

The 4-20 mA input needs to be calibrated to the actual milliamp input to be accurate. A milliamp meter is necessary to calibrate the 4-20 mA input. Connect the milliamp meter in-line with one leg of the 4-20 mA input. Refer to the drawing in the back of this manual for wiring instructions.

- From the **4-20 mA Setup** screen, press "3" **CALIBRATE**.
- Use the keypad to enter the milliamp reading from the milliamp meter. Press "ENT".

6.5.6 The System Setup Menu

The system setup menu is used to set up the temperature compensation, damping, initialize the controller, change the security password, check the firmware version, check the diagnostics, and select the controller model.

To reach the **SYSTEM SETUP MENU**:

- From the **MAIN MENU** press “**7**” **SYSTEM SETUP**. The following screen will appear.

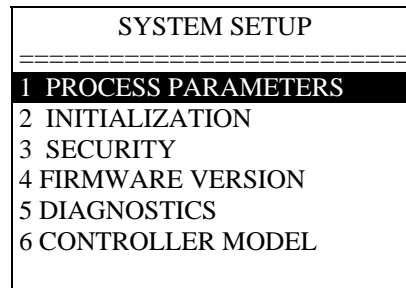

6.5.6.1 Process Parameters

The process parameters screen is used to set up the damping, temperature compensator, and set the amount of temperature compensation. The **PROCESS PARAMETER** screen is shown below.

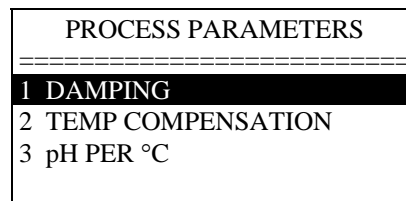

6.5.6.1.1 Damping

Damping is used to slow down the rate of change of the pH or ORP reading in cases where the reading is changing rapidly. The default setting is 0.5 seconds. The larger the time, the slower the readings will change.

To change the damping value.

- From the **PROCESS PARAMETERS** screen, press “**1**” **DAMPING**.
- Use the keypad to change the damping time and press “**ENT**”.

6.5.6.1.2 Temperature Compensation

The model 1520/30e can accept a 10K PTC or 3K PTC temperature compensated or non-temperature compensated pH or ORP input. The temperature compensation for your sensor must be set in the model 1520/30e controller. Refer to the manufacturers information for the temperature compensation values for your pH or ORP sensor.

To set up the temperature compensation:

- From the Main Menu press **"7" SYSTEM SETUP.**
- Press **"1" PROCESS PARAMETERS.**
- Press **"2" TEMP COMPENSATION**
- Press **"1" for NONE.** Press **"2" for 3k PTC.** Press **"3" for 10K PTC.**

TEMPERATURE COMPENSATION
=====
1* NONE
2 3K PTC
3 10K PTC

6.5.6.1.3 pH per 10°C

The model 1520/30e has the ability to change the amount of temperature compensation for each °C temperature change.

To change the amount of temperature compensation:

- From the Main Menu press **"7" SYSTEM SETUP.**
- Press **"1" PROCESS PARAMETERS.**
- Press **"3" pH per 10°C**
- Use the keypad to enter a value for the amount of temperature compensation. Press **"ENT"**.

6.5.6.2 Initialization

Initialization restores the factory default settings to the controller. The whole controller can be initialized or just the calibration. It is suggested that you initialize the whole controller before you program the controller. This will clear any random settings that may be in the controller. To do so, follow these instructions:

- From the **Main Menu**, press **"7"** **SYSTEM SETUP**.
- Press **"2"** **INITIALIZATION**.
- Press **"2"** **WHOLE CONTROLLER** and press **"ENT"**. A warning will appear on the screen (see below). Press **"1"** to proceed, **"2"** to cancel.

WARNING: THIS OPTION MAY REQUIRE YOU TO RE-CALIBRATE THE CONTROLLER. ARE YOU SURE?
1 YES
2 NO

To initialize just the calibration:

- Press **"1"** **CALIBRATIONS** instead of **"2"** **WHOLE CONTROLLER** in the procedure above. The same warning screen will appear.

6.5.6.3 Change the Security Password

The security password can be changed from the factory default setting of 2222 to any four-digit value that you desire.

To change the security password:

- From the **Main Menu**, press **"7"** **SYSTEM SETUP**.
- Press **"3"** **SECURITY**.
- Use the keypad to enter the old password. If the password has not been changed before, the old password is **2222**.
- Use the keypad to enter the new password.
- Use the keypad to enter the new password a second time for verification

If you lose your password, contact Lakewood Instruments for assistance.

PASSWORDS ARE 4 KEYS ENTER A NEW PASSWORD
OLD PASSWORD=****
NEW PASSWORD=****
VERIFY =
CLR= EXIT

6.5.6.4 Firmware Version

Sometimes it is necessary to verify the firmware version of the controller for troubleshooting purposes. To get to the firmware version:

- From the **Main Menu**, press **”7”** **SYSTEM SETUP**.
- Press **”4”** **FIRMWARE VERSION**.
- The firmware version will be displayed along with a checksum value. The checksum value is used to verify that the program has not been corrupted. To exit this screen, press any key.

6.5.6.5 Diagnostics

The diagnostics screen is used for troubleshooting purposes. Contact Lakewood Instruments for assistance.

6.5.6.6 Controller Model

The model 1520/30e can be used for either pH (model 1520) or for ORP (model 1530). The **CONTROLLER MODEL** screen is used to configure the controller for pH or ORP.

To change the controller model:

- From the **Main Menu**, press **”7”** **SYSTEM SETUP**.
- Press **”6”** **CONTROLLER MODEL**.
- Press **“1”** **1520 (pH)** or **“2”** **1530 (ORP)**.

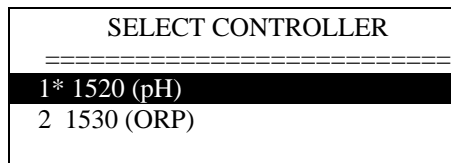

6.5.7 Setting the Clock

The clock uses the 24 hour or military time. 06:00:00 is 6 a.m. 18:00:00 is 6 p.m. To set the clock:

- From the **Main Menu** press **”8”** **CLOCK**. The following screen will appear:

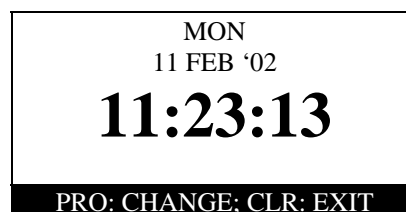

- Press "**PRO**" to change the clock settings.
- Use the up and down arrow keys to change the day of the week. Press "**ENT**".
- Use the number keys to change the date. Press "**ENT**".
- Use the arrow keys to change the month. Press "**ENT**".
- Use the number keys to change the year. Press "**ENT**".
- Use the number keys to change the hour. Press "**ENT**".
- Use the number keys to change the minutes. Press "**ENT**".
- Use the number keys to change the seconds. Press "**ENT**".
- Press "**CLR**" to exit this screen.

You must press "**ENT**" all the way through this menu for the settings to take affect.

6.5.8 Changing the Security Levels

The security level can be change to prevent any unwanted tampering of the controller. To change the security level from **Technician** to **View-Only**:

- From the **Main Menu**, press "**0**". (*Note that "0" does not appear on the menu screen.*)

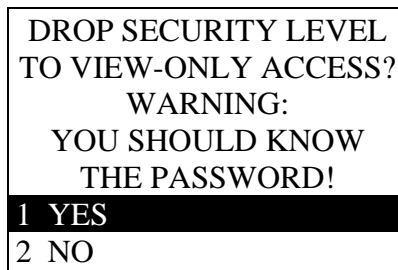

- Select **YES** to change the security level. You will see the following screen:



The controller menu now functions at the **VIEW-ONLY** security level.

To return to the **Technician** security level:

- Press the numeric password from any **Process** screen. You will see the following:



Remember that following the first power-up the Technician password is 2222. You may change the passwords in the **SYSTEM SETUP** menu.

7.0 Maintenance

Periodic maintenance is required to ensure trouble free operation of the model 1520/30e controller. The following sections cover the required maintenance.

7.1 Sensor Maintenance

Routine maintenance is necessary in order to maximize the efficiency and accuracy of your sensor. Clean the electrode end of the pH or ORP sensor at least once per month. Cleaning of the pH or ORP sensor may need to be performed more frequently if it is in an environment which causes frequent fouling of the sensor.

- Remove power from the controller and shut off the sample flow.
- Remove the sensor from its plumbing.
- Flush the sensor tip with tap water. Do not use cloth to clean the sensor tip. Cloth has oils that will foul the sensor.
- If there is oil on the sensor tip, use isopropyl alcohol to clean the tip. If necessary determine the source of oil contamination and correct.
- If there is scale on the sensor tip use a 10% Muriatic or HCl acid to clean the sensor.
- If necessary, a cotton swab can be used to clean the reference junction of the sensor. Avoid contact with the glass as much as possible.
- Wash the sensor off with tap water.
- Install the sensor in its plumbing.
- Restore sample flow and check for leaks.
- Restore power to the controller and allow the reading to stabilize.
- Perform a calibration of the pH or ORP.
- Verify operation before leaving the area.

7.2 Flow Switch Maintenance

If you have the flow switch plumbing assembly, you may need to periodically clean the wetted parts in this assembly.

- Shut off the inlet flow and the power to the controller.
- Turn the red lock ring for the flow switch counterclockwise.
- Pull out the clear flowsight tube and remove the float with your fingers.
- Use a bottlebrush on the float, flowsight and the flow switch assembly to remove any residue.
- Clean and lubricate the “O” ring with a silicone-based lubricant (petroleum-based lubricants will cause the O-ring to swell).
- Lock down the red lock ring after you replace the components.
- Turn the inlet flow back on and check for leaks.

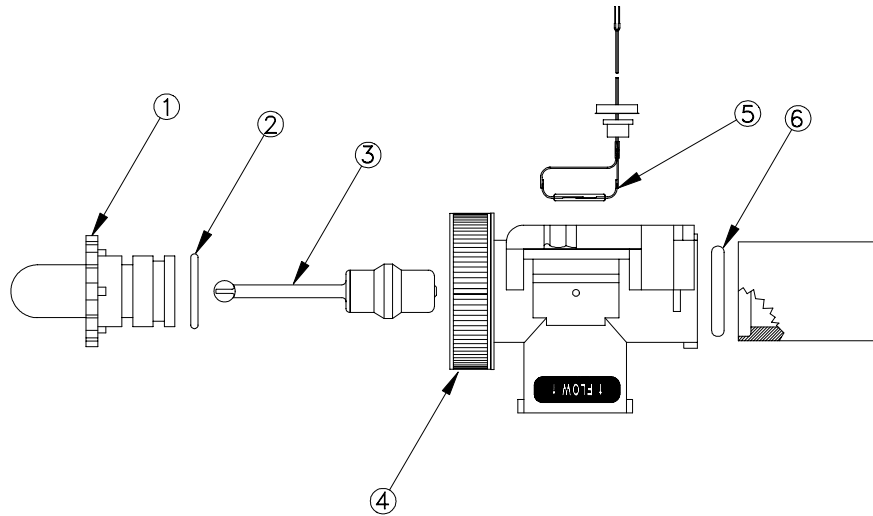

FlowSwitchAssembly, P/N 1240477

Find No.	Part No.	Part Description
1	1167266	Flowsight
2	1166418	O-Ring (flow sight)
3	1167234	Flow Magnet
4	1169740	Red Locking Ring Kit
5	1107004	Reed Switch
6	1166417	O-Ring (check valve)

Replacing the Reed Switch

If you ever need to replace the reed switch for the flow switch, follow the procedure below.

- Remove the power to the controller and shut off the sample flow.
- Disconnect the flow switch wires from the controller.
- Remove the screws holding the flow switch plumbing assembly.
- Move the flow switch plumbing assembly away from the wall.
- Pull hard on the wires that go to the reed switch assembly to remove the reed switch.
- Push the new reed switch into the plumbing assembly and wire the new reed switch to the controller.
- Re-install plumbing.
- Restore flow to the plumbing assembly and check for leaks.
- Restore power to the controller.
- Verify operation before leaving the area.

7.3 Replacing the Fuses

The Model 1520/30e contains a two 5 x 20 mm, European-style fuses. Replacement fuses must be a Schurter 0034.1526, Littlefuse 217.010, or equivalent 10A, 250V, fast blow type for Fuse F1 and a Littlefuse 218.100, Schurter 0034.3107, or equivalent 100mA, slow blow for Fuse F2. If a fuse is blown, the display will be blank when the unit is connected to power. Refer to the troubleshooting section of this manual for more information about blank displays.

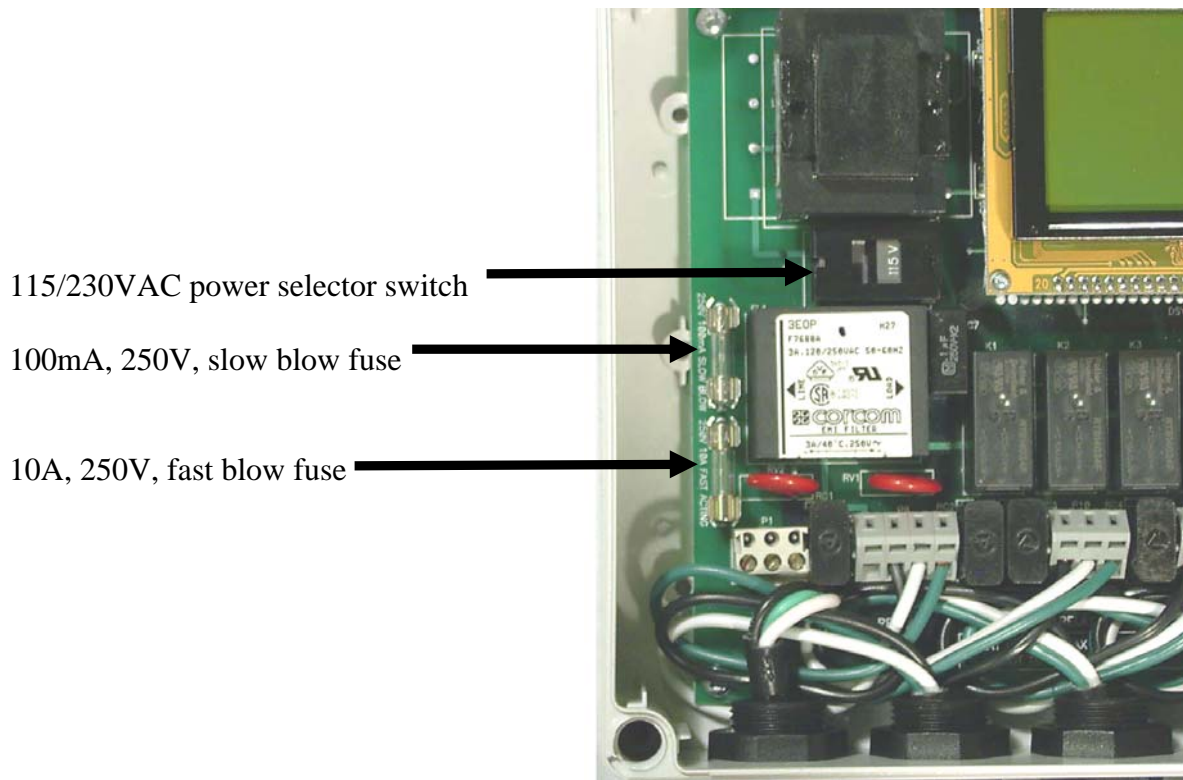

8.0 Troubleshooting

8.1 Error Messages

This section discusses some of the more common questions with the Model 1520/30e. These notes are not intended to be all-inclusive—only to cover the most common situations. If you have other questions or are need support, contact the Lakewood Instruments Technical Service Department toll free at (800) 228-0839.

PROBLEM	WHAT THIS MEANS	CORRECTIVE ACTION
{Alarm Flashing} “PH OR ORP HIGH” OR “PH OR ORP LOW”	PH or ORP is too high or low with respect to the high or low alarm setpoint.	<ol style="list-style-type: none"> 1. See problem “RELAY TIMEOUT”. 2. Check the chemical pump operation. 3. The chemical drum is empty. 4. Check the High or Low Alarm Value. 5. Check relay setpoints and deadbands. 6. Insure the system is not overflowing.
Water meters not accumulating.	<p>There may be a problem with the wiring or the reed switch in the meter may be bad.</p> <p>For water meters other than the contacting head type, check the manufacturer’s user manual for that particular water meter.</p>	<ol style="list-style-type: none"> 1. Approximately 5 volts DC should be present at the input terminal when the water meter contact is closed. That should change to zero VDC when the contact opens. Check these voltages and for correct wiring. 2. Is the controller configured for your type of water meter?
{Alarm Flashing} “FEED SEQUENCE ACTIVE”.	This simply indicates that a feed schedule relay is active.	No action necessary.
Display is blank.	There may be a problem with the incoming power, the fuses or the circuit board. Open the front panel to troubleshoot.	<ol style="list-style-type: none"> 1. Check the fuse F1. Replace with 5 x 20 mm, 10A, 250V, fast blow fuse. 2. Check the fuse F2. Replace with 5 x 20 mm, 100mA, 250V, slow blow fuse. 3. Does the unit have power? 4. If there is power to terminals AC and ACC on P1, call Lakewood Instruments Technical Service for more information.
“NO FLOW” alarm.	Flow input switch is not closed.	<ol style="list-style-type: none"> 1. The flow switch float may be stuck or no flow is present. 2. Flow switch may be bad. Replace reed switch in plumbing assembly. <p>If no flow switch is used, a jumper wire should be installed across the flow switch input. Removing the jumper disables all relay outputs.</p>

PROBLEM	WHAT THIS MEANS	CORRECTIVE ACTION
<p>{Alarm Flashing} “RELAY TIMEOUT”.</p>	<p>This indicates that the controller has been trying to operate a relay for longer than the user-programmed time and is unable to reach the setpoint.</p>	<ol style="list-style-type: none"> 1. Check for proper operation of the pump or valve. Use the manual relay control to help. 2. Check the relay configuration and verify settings. 3. Check chemical levels in the drums or totes. 4. Verify operation of water meters. 5. Momentarily shut off system flow to reset alarms.
<p>{Alarm Flashing} “OPENED TC”.</p>	<p>Temperature compensator not being properly read.</p>	<ol style="list-style-type: none"> 1. Check sensor wiring. 2. Verify Temperature Compensation setting in the Process Parameters screen. 2. Replace pH or ORP sensor.
<p>{Alarm Flashing} “SHORTED TC”.</p>	<p>Temperature compensator not being properly read.</p>	<ol style="list-style-type: none"> 1. Check sensor wiring. 2. Verify Temperature Compensation setting in the Process Parameters screen. 3. Replace pH or ORP sensor.
<p>Motorized ball valve functions, but will not remain “open” or “closed” as expected.</p>	<p>The motorized ball valve is not indicating to the 1520/30e that it has actually reached the open or closed position.</p>	<p>Adjust the limit switch for the motorized ball valve.</p>
<p>Deviation >1.5 pH from default or Deviation >200mV from default</p>	<p>You are trying to calibrate the controller to a value that is too far from the value the controller expects based on the input from the sensor.</p>	<ol style="list-style-type: none"> 1. Initialize the calibrations and try again. 2. Check sensor operation in a cup of the system water or buffer. 3. Clean sensor.
<p>Calibration points less than 2 pH (200 mV) apart</p>	<p>You are trying to perform a two point calibration with two solutions that are too close to the same reading to allow a good calibration to occur.</p>	<ol style="list-style-type: none"> 1. For a pH two point calibration, the two solutions must be at least two pH apart. 2. For an ORP two point calibration, the two solutions must be at least 200 mV apart.

9.0 Factory Service

-  Technical Support for Lakewood Instruments can be reached by calling (800) 228-0839 or faxing (414) 355-3508, Monday through Friday, 7:30 a.m. - 5:00 p.m. CST.

NOTE: IF YOU CALL FOR TROUBLESHOOTING HELP, PLEASE HAVE THE MODEL NUMBER, SERIAL NUMBER, AND ANY OPTIONS PERTAINING TO YOUR UNIT AVAILABLE FOR REFERENCE.

-  Mail and returns should be sent to:

**Lakewood Instruments
7838 North Faulkner Road
Milwaukee, WI 53224 USA**

When any merchandise is to be returned to the factory, please call and obtain a Return Goods Authorization (RGA) number and have the following information available:

- Customer's name, address, telephone and fax numbers (shipping and billing).
- A hard copy purchase order number for cases where repairs or parts are required that are not under warranty.
- A contact person's name and telephone number to call if the equipment is beyond repair or to discuss any other warranty matter.
- Equipment model and serial numbers.
- Reason for return, e.g., repair, warranty, incorrect part, etc.

We will then fax to your attention an RGA form that must accompany the returned item.

NOTE: THE RGA NUMBER MUST BE CLEARLY WRITTEN ON THE OUTSIDE OF THE PACKAGE(S) BEING RETURNED.

**ANY ITEMS SENT BACK TO THE FACTORY
WITHOUT AN RGA NUMBER WILL BE REFUSED
AND RETURNED TO SENDER**

Service Guide

When calling Lakewood Instruments, please have your controller's complete model number and serial number available, together with the firmware version so that the Technician can better assist you.

Refer to the Ordering Information section of this manual for part numbered replacement parts.

Write your controller's complete model number, serial number, and firmware version here so that you will have them available if you wish to contact a Lakewood Instruments technician.

Model Number:

Serial Number:

Firmware Version:

10.0 Drawings

REVISION		REVISION HISTORY			
DWG	PART	DESCRIPTION	ECO	DWN/DATE	APVD/DATE
B	A	UPDATED PLUMBING	8452	DGK/2/11/04	LRS/2/11/04

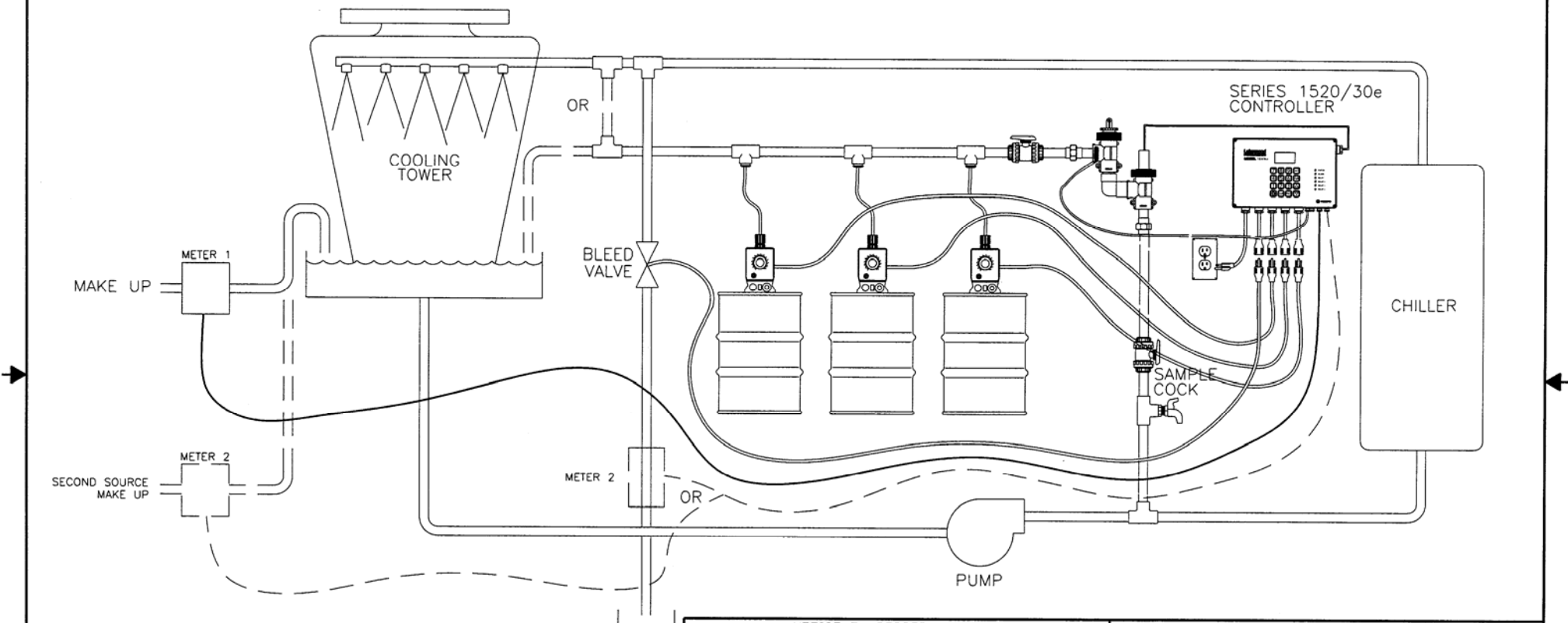

NOTICE ON REPRODUCTIONS
 THIS DRAWING, THE DESIGN AND THE PATENTS IT COVERS, ARE THE PROPERTY OF OSMONICS INC. THEY ARE LOANED MERELY AND ON THE BORROWER'S EXPRESS AGREEMENT THAT THEY WILL NOT BE REPRODUCED, COPIED, LOANED, EXHIBITED, NOR USED EXCEPT IN THE LIMITED WAY AND THE PRIVATE USE PERMITTED BY WRITTEN CONSENT GIVEN BY THE LENDER TO THE BORROWER.

DIMENSIONING AND TOLERANCING PER ASME Y14.5M-1994

MATERIAL	N/A	TOLERANCES UNLESS NOTED
		DECIMALS ±
		ANGLES ±
		.XX ± SURFACE
		.XXX ±

FINISH	N/A	DWN	DGK	DATE	2/11/04
		CHKD	PEP	DATE	2/11/04
PROJECT:	N/A	APVD	LRS	DATE	2/11/04
LIBRARY:	N/A	PART	VERSION	N/A	



TITLE		INSTALLATION DRAWING COOLING TOWER, 1520/30e	
SIZE	B	PN	1220993
SCALE	NTS	SHEET	1 OF 1
DWG NO	1207156	REV	A
		REV	B

REVISION		REVISION HISTORY			
DWG	PART	DESCRIPTION	ECO	DWN/DATE	APVD/DATE
B	A	Update Plumbing	8452	DGK/2/11/04	LRS/2/11/04

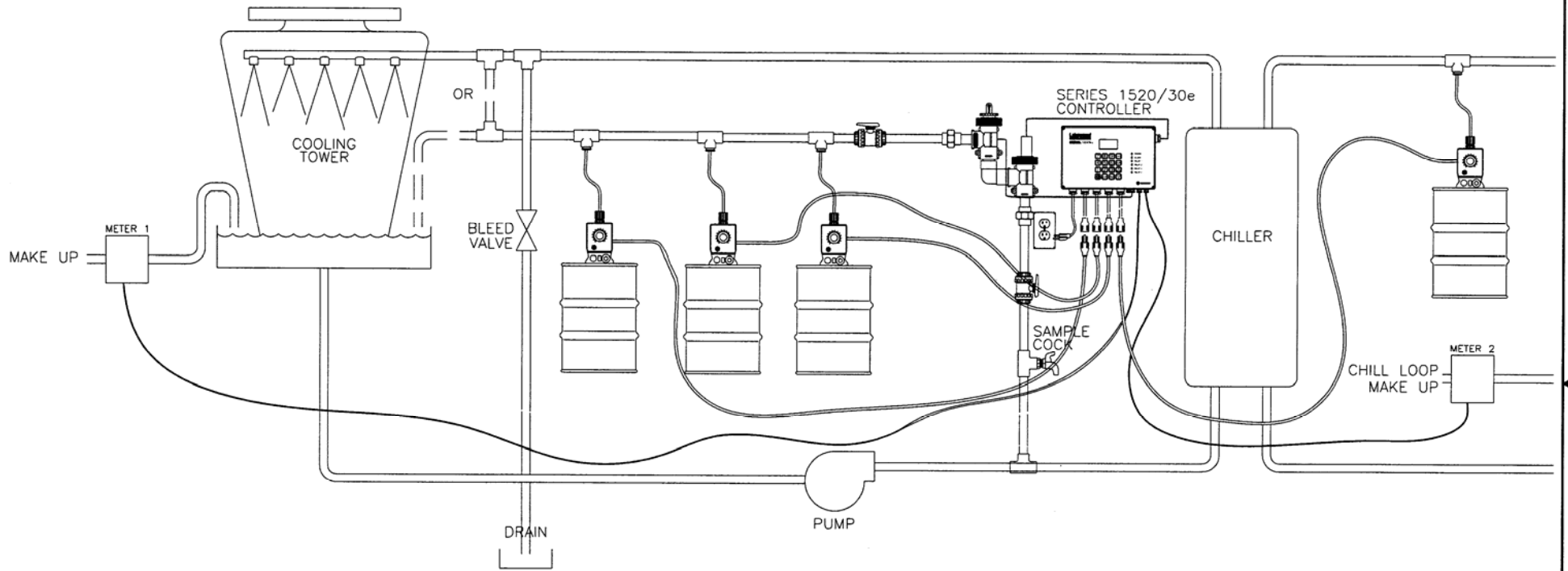

<p>NOTICE ON REPRODUCTIONS THIS DRAWING, THE DESIGN AND THE PATENTS IT COVERS, ARE THE PROPERTY OF OSMONICS INC. THEY ARE LOANED MERELY AND ON THE BORROWER'S EXPRESS AGREEMENT THAT THEY WILL NOT BE REPRODUCED, COPIED, LOANED, EXHIBITED, NOR USED EXCEPT IN THE LIMITED WAY AND THE PRIVATE USE PERMITTED BY WRITTEN CONSENT GIVEN BY THE LENDER TO THE BORROWER.</p>					
<p>DIMENSIONING AND TOLERANCING PER ASME Y14.5M-1994</p>				<p>TITLE INSTALLATION DRAWING 1520/30e, CHILLI LOOP /COOLING</p>	
MATERIAL	N/A	<p>TOLERANCES UNLESS NOTED</p> <p>DECIMALS ± .XX ± .XXX ±</p> <p>ANGLES ± SURFACE ✓</p>		<p>SIZE B</p> <p>THIRD ANGLE</p>	
FINISH	N/A	DWN DGK	DATE 2/11/04	PN	1220993
		CHKD PEP	DATE 2/11/04	DWG NO	1207157
PROJECT:	N/A	APVD LRS	DATE 2/11/04	SCALE	NTS
LIBRARY:	N/A	PART VERSION	N/A	SHEET	1 OF 1
				REV	A
				REV	B

REVISION		REVISION HISTORY			
DWG	PART	DESCRIPTION	ECO	DWN/DATE	APVD/DATE
B	A	RELEASE	8452	DGK/2/11/04	LRS/2/11/04

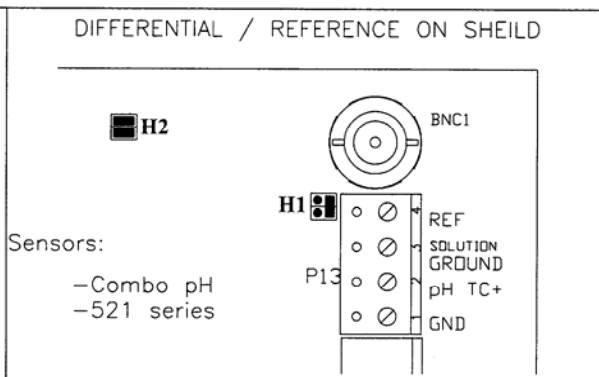
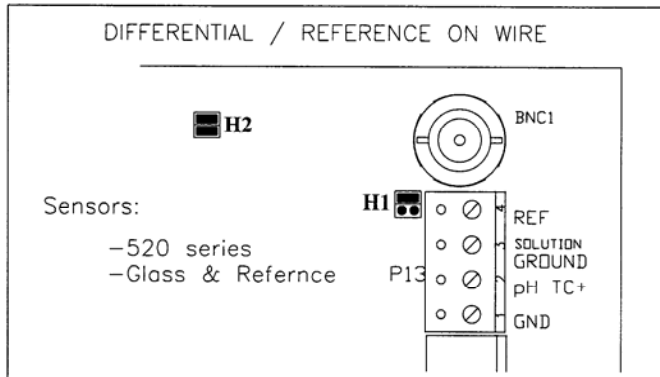

pH JUMPER CONFIGURATIONS

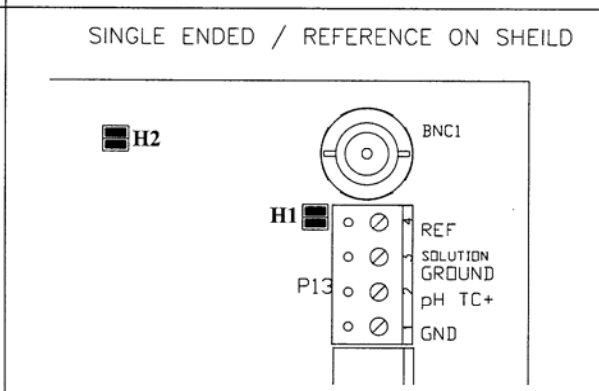
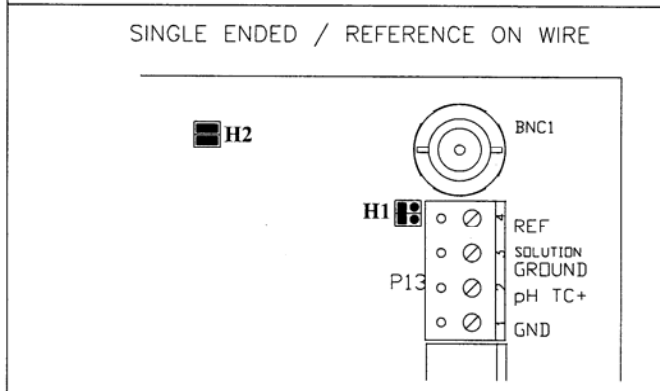

NOTICE ON REPRODUCTIONS					
THIS DRAWING, THE DESIGN AND THE PATENTS IT COVERS, ARE THE PROPERTY OF OSMONICS INC. THEY ARE LOANED MERELY AND ON THE BORROWER'S EXPRESS AGREEMENT THAT THEY WILL NOT BE REPRODUCED, COPIED, LOANED, EXHIBITED, NOR USED EXCEPT IN THE LIMITED WAY AND THE PRIVATE USE PERMITTED BY WRITTEN CONSENT GIVEN BY THE LENDER TO THE BORROWER.					
DIMENSIONING AND TOLERANCING PER ASME Y14.5M-1994					
MATERIAL	N/A	TOLERANCES UNLESS NOTED		TITLE	
		DECIMALS	ANGLES	1520/30e	
		.X ±	±	pH JUMPER CONFIGURATIONS	
		.XX ±	SURFACE	PN	
		.XXX ±	✓	SIZE	1220993
FINISH	N/A	DWN	DGK	DATE	2/11/04
		CHKD	PEP	DATE	2/11/04
PROJECT:	N/A	APVD	LRS	DATE	2/11/04
LIBRARY:	N/A	VERSION		N/A	
		SCALE	NTS	SHEET	1 OF 1
				DWG NO	1207169
				REV	A
				REV	B



REVISION		REVISION HISTORY			
DWG	PART	DESCRIPTION	ECO	DWN/DATE	APVD/DATE
B	A	RELEASE	8452	DGK/2/11/04	LRS/2/11/04

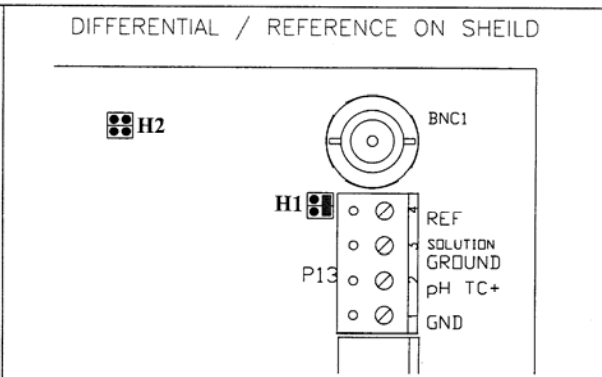
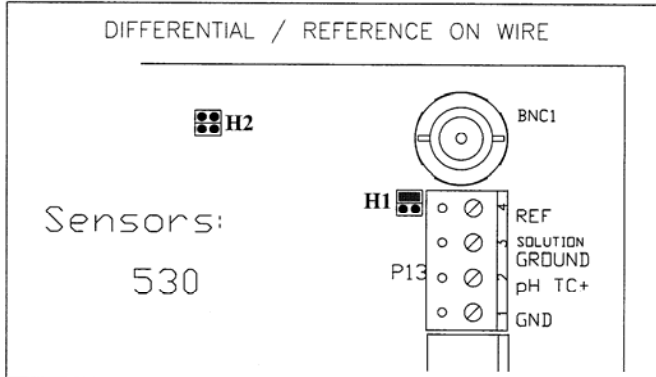

ORP JUMPER
CONFIGURATIONS

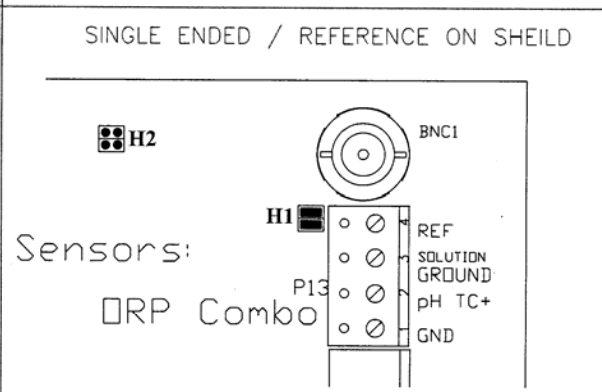
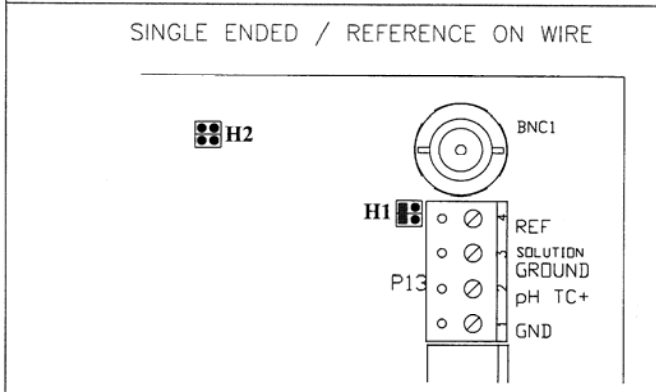

NOTICE ON REPRODUCTIONS
THIS DRAWING, THE DESIGN AND THE PATENTS IT COVERS, ARE THE PROPERTY OF OSMONICS INC. THEY ARE LOANED MERELY AND ON THE BORROWER'S EXPRESS AGREEMENT THAT THEY WILL NOT BE REPRODUCED, COPIED, LOANED, EXHIBITED, NOR USED EXCEPT IN THE LIMITED WAY AND THE PRIVATE USE PERMITTED BY WRITTEN CONSENT GIVEN BY THE LENDER TO THE BORROWER.



DIMENSIONING AND TOLERANCING PER ASME Y14.5M-1994

MATERIAL	N/A	TOLERANCES UNLESS NOTED
		DECIMALS ±
		ANGLES ±
		.XX ±
		.XXX ±
		SURFACE ✓

FINISH	N/A	DWN	DGK	DATE	2/11/04
		CHKD	PEP	DATE	2/11/04
PROJECT:	N/A	APVD	LRS	DATE	2/11/04
LIBRARY:	N/A	PART VERSION	N/A		

TITLE	1520/30e ORP JUMPER CONFIGURATIONS		
SIZE	B	PN	1220993
THIRD ANGLE		REV	A
SCALE	NTS	DWG NO	1207168
SHEET	1 OF 1	REV	B

REVISION		REVISION HISTORY			
DWG	PART	DESCRIPTION	ECD	DWN/DATE	APVD/DATE
A	A	RELEASE	8452	DGK/2/11/04	LRS/2/11/04

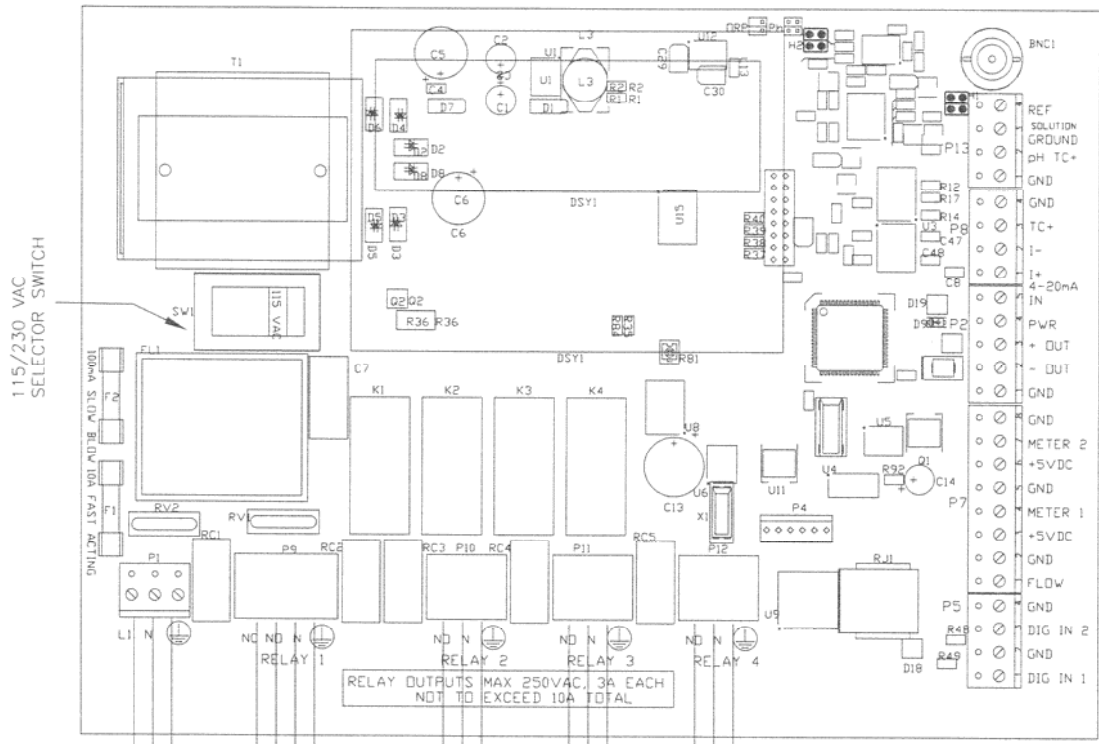

115/230 VAC
SELECTOR SWITCH

115/230VAC/50-60 HZ
(COM)
(E GND)

RLY1 HOT (NC)
RLY1 HOT (NO)
RLY1 (COM)
(E GND)

MOTORIZED BALL VALVE OR SOLENOID VALVE OR CHEM PUMPS/ALARM OUTPUTS

RELAY OUTPUTS MAX 250VAC, 3A EACH NOT TO EXCEED 10A TOTAL

RLY2 HOT (NO)
(COM)
(E GND)

CHEM PUMPS/ALARM OUTPUTS

RLY3 HOT (NO)
(COM)
(E GND)

RLY4 HOT (NO)
(COM)
(E GND)

NOTICE ON REPRODUCTIONS				OSMONICS MILWAUKEE OPERATIONS	
THIS DRAWING, THE DESIGN AND THE PATENTS IT COVERS, ARE THE PROPERTY OF OSMONICS INC. THEY ARE LOANED MERELY AND ON THE BORROWER'S EXPRESS AGREEMENT THAT THEY WILL NOT BE REPRODUCED, COPIED, LOANED, EXHIBITED, NOR USED EXCEPT IN THE LIMITED WAY AND THE PRIVATE USE PERMITTED BY WRITTEN CONSENT GIVEN BY THE LENDER TO THE BORROWER.				TITLE WIRING DIAGRAM FOR THE 1520/30e POWER CONNECTIONS	
DIMENSIONING AND TOLERANCING PER ASME Y14.5M-1994				SIZE B	
MATERIAL	N/A	TOLERANCES UNLESS NOTED DECIMALS .X ± .XX ± .XXX ±		PN 1220993	
FINISH	N/A	DWN DGK DATE 2/11/04	CHKD PEP DATE 2/11/04	SCALE NTS	
PROJECT:	N/A	APVD LRS DATE 2/11/04	SHEET 1 OF 1		DWG NO 1207179
LIBRARY:	N/A	PART VERSION N/A		REV A	

REVISION		REVISION HISTORY			
DWG	PART	DESCRIPTION	ECD	DWN/DATE	APVD/DATE
A	A	RELEASE	8452	BGK/2/11/04	LRS/2/11/04

NOTES: UNLESS OTHERWISE SPECIFIED;
 ⚠ IF NO FLOW SWITCH IS USED, SHORT OUT PINS 1 & 2 WITH WIRE.

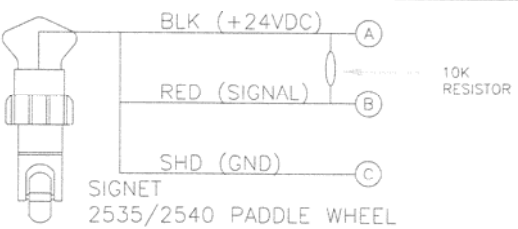
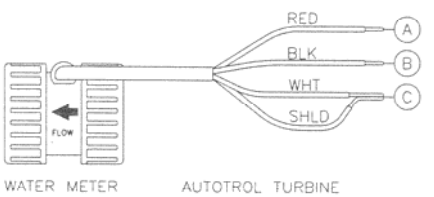
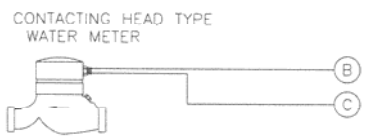
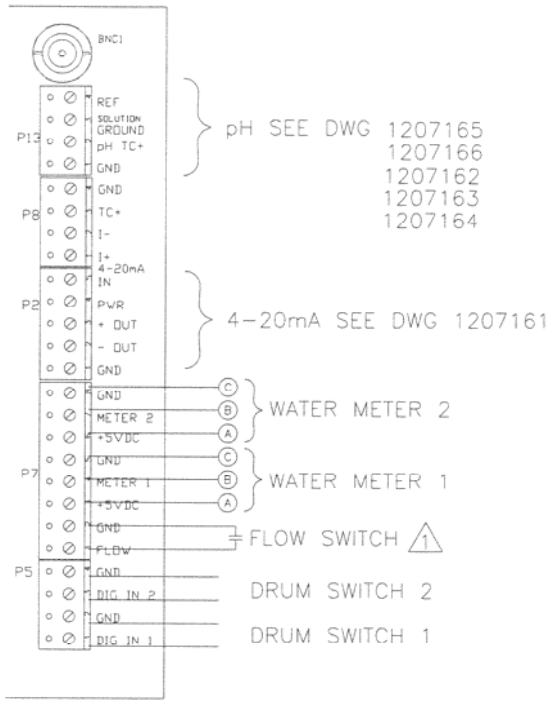

NOTICE ON REPRODUCTIONS
 THIS DRAWING, THE DESIGN AND THE PATENTS IT COVERS, ARE THE PROPERTY OF OSMONICS INC. THEY ARE LOANED MERELY AND ON THE BORROWER'S EXPRESS AGREEMENT THAT THEY WILL NOT BE REPRODUCED, COPIED, LOANED, EXHIBITED, NOR USED EXCEPT IN THE LIMITED WAY AND THE PRIVATE USE PERMITTED BY WRITTEN CONSENT GIVEN BY THE LENDER TO THE BORROWER



DIMENSIONING AND TOLERANCING PER ASME Y14.5M-1994			
MATERIAL	N/A	TOLERANCES UNLESS NOTED DECIMALS: X ±, .XX ±, .XXX ± ANGLES: ± SURFACE: ✓	
FINISH	N/A	DWN	BGK DATE 2/11/04
		CHKD	PEP DATE 2/11/04
PROJECT:	N/A	APVD	LRS DATE 2/11/04
LIBRARY:	N/A	PART VERSION	N/A

TITLE			
WIRING DIAGRAM FOR WATER METER INPUTS ON THE 1520/30e			
SIZE	B	PN	1220993
THIRD ANGLE		DWG NO	1207167
SCALE	NTS	SHEET	1 OF 1
REV	A		

REVISION		REVISION HISTORY			
DWG	PART	DESCRIPTION	ECD	DWN/DATE	APVD/DATE
B	A	RELEASE	8452	DGK/2/11/04	LRS/2/11/04

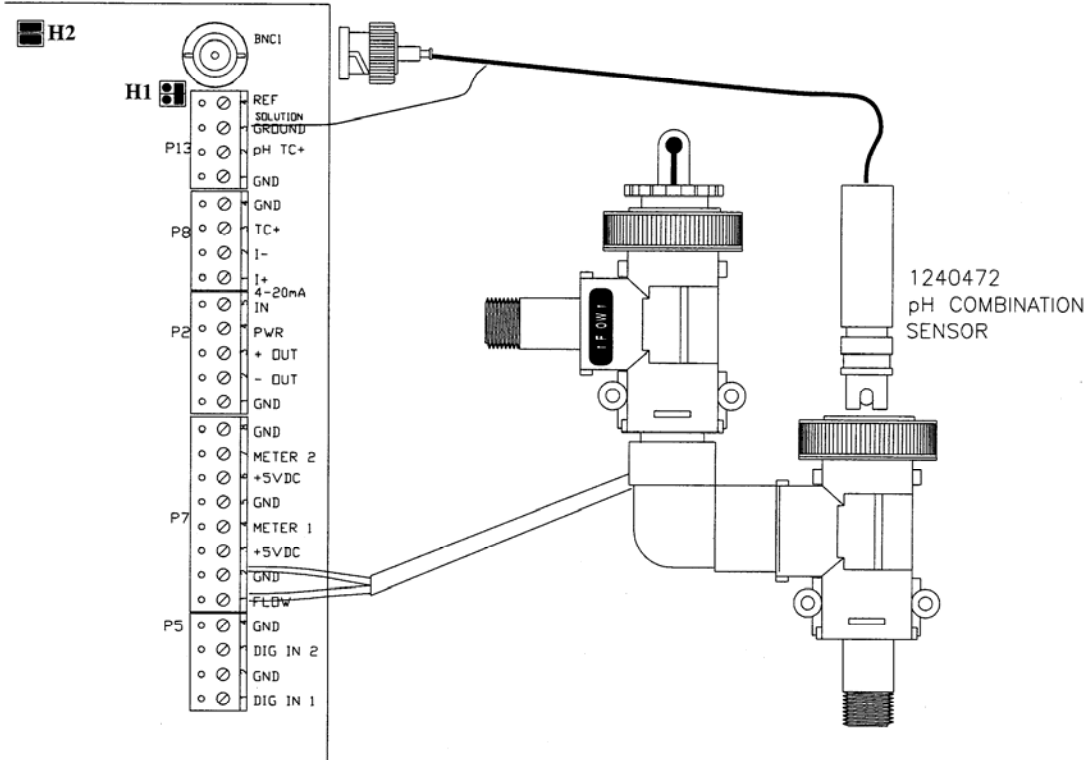

<p>NOTICE ON REPRODUCTIONS THIS DRAWING, THE DESIGN AND THE PATENTS IT COVERS, ARE THE PROPERTY OF OSMONICS INC. THEY ARE LOANED MERELY AND ON THE BORROWER'S EXPRESS AGREEMENT THAT THEY WILL NOT BE REPRODUCED, COPIED, LOANED, EXHIBITED, NOR USED EXCEPT IN THE LIMITED WAY AND THE PRIVATE USE PERMITTED BY WRITTEN CONSENT GIVEN BY THE LENDER TO THE BORROWER.</p>														
<p>DIMENSIONING AND TOLERANCING PER ASME Y14.5M-1994</p>				<p>TITLE pH COMBINATION SENSOR WIRING 1520/30e</p>										
MATERIAL	N/A	<p>TOLERANCES UNLESS NOTED</p> <table border="0"> <tr> <td>DECIMALS</td> <td>ANGLES</td> </tr> <tr> <td>X ±</td> <td>±</td> </tr> <tr> <td>.XX ±</td> <td>SURFACE</td> </tr> <tr> <td>.XXX ±</td> <td>✓</td> </tr> </table>		DECIMALS	ANGLES	X ±	±	.XX ±	SURFACE	.XXX ±	✓	SIZE	PN	REV
DECIMALS	ANGLES													
X ±	±													
.XX ±	SURFACE													
.XXX ±	✓													
FINISH	N/A	DWN	DGK	DATE	2/11/04	B	1220993	A						
PROJECT:	N/A	CHKD	PEP	DATE	2/11/04	<p>THIRD ANGLE</p>								
LIBRARY:	N/A	APVD	LRS	DATE	2/11/04	SCALE	SHEET	DWG NO						
						NTS	1 OF 1	1207165						
		PART VERSION	N/A					B						

REVISION		REVISION HISTORY			
DWG	PART	DESCRIPTION	ECD	DWN/DATE	APVD/DATE
B	A	RELEASE	8452	DGK/2/11/04	LRS/2/11/04

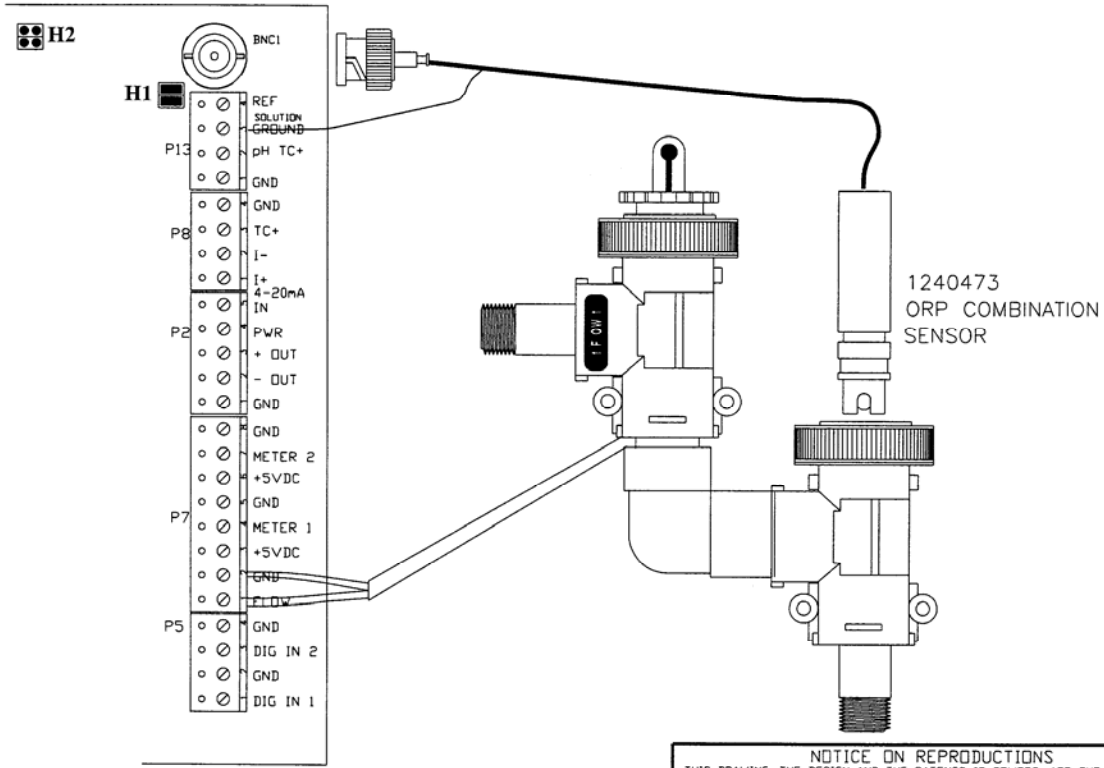

<p>NOTICE ON REPRODUCTIONS THIS DRAWING, THE DESIGN AND THE PATENTS IT COVERS, ARE THE PROPERTY OF OSMONICS INC. THEY ARE LOANED MERELY AND ON THE BORROWER'S EXPRESS AGREEMENT THAT THEY WILL NOT BE REPRODUCED, COPIED, LOANED, EXHIBITED, NOR USED EXCEPT IN THE LIMITED WAY AND THE PRIVATE USE PERMITTED BY WRITTEN CONSENT GIVEN BY THE LENDER TO THE BORROWER.</p>																			
<p>DIMENSIONING AND TOLERANCING PER ASME Y14.5M-1994</p>				<p>TITLE ORP COMBINATION SENSOR WIRING 1520/30e</p>															
MATERIAL	N/A	<p>TOLERANCES UNLESS NOTED</p> <table border="0"> <tr> <td>DECIMALS</td> <td>ANGLES</td> </tr> <tr> <td>.X ±</td> <td>± SURFACE</td> </tr> <tr> <td>.XX ±</td> <td></td> </tr> <tr> <td>.XXX ±</td> <td></td> </tr> </table>				DECIMALS	ANGLES	.X ±	± SURFACE	.XX ±		.XXX ±							
DECIMALS	ANGLES																		
.X ±	± SURFACE																		
.XX ±																			
.XXX ±																			
FINISH	N/A	<table border="0"> <tr> <td>DWN</td> <td>DGK</td> <td>DATE</td> <td>2/11/04</td> </tr> <tr> <td>CHKD</td> <td>PEP</td> <td>DATE</td> <td>2/11/04</td> </tr> </table>	DWN	DGK	DATE	2/11/04	CHKD	PEP	DATE	2/11/04	<table border="0"> <tr> <td>SIZE</td> <td rowspan="2"></td> <td>PN</td> <td rowspan="2">1220993</td> <td>REV</td> <td rowspan="2">A</td> </tr> <tr> <td>B</td> <td></td> </tr> </table>	SIZE		PN	1220993	REV	A	B	
DWN	DGK	DATE	2/11/04																
CHKD	PEP	DATE	2/11/04																
SIZE		PN	1220993	REV	A														
B																			
PROJECT:	N/A	<table border="0"> <tr> <td>APVD</td> <td>LRS</td> <td>DATE</td> <td>2/11/04</td> </tr> </table>	APVD	LRS	DATE	2/11/04	<table border="0"> <tr> <td>SCALE</td> <td>SHEET</td> <td>DWG NO</td> <td rowspan="2">1207166</td> <td>REV</td> <td rowspan="2">B</td> </tr> <tr> <td>NTS</td> <td>1 OF 1</td> </tr> </table>	SCALE	SHEET	DWG NO	1207166	REV	B	NTS	1 OF 1				
APVD	LRS	DATE	2/11/04																
SCALE	SHEET	DWG NO	1207166	REV	B														
NTS	1 OF 1																		
LIBRARY:	N/A	PART VERSION N/A																	

REVISION		REVISION HISTORY			
DWG	PART	DESCRIPTION	ECD	DWN/DATE	APVD/DATE
A	A	RELEASE	B452	DGK/2/11/04	LRS/2/11/04

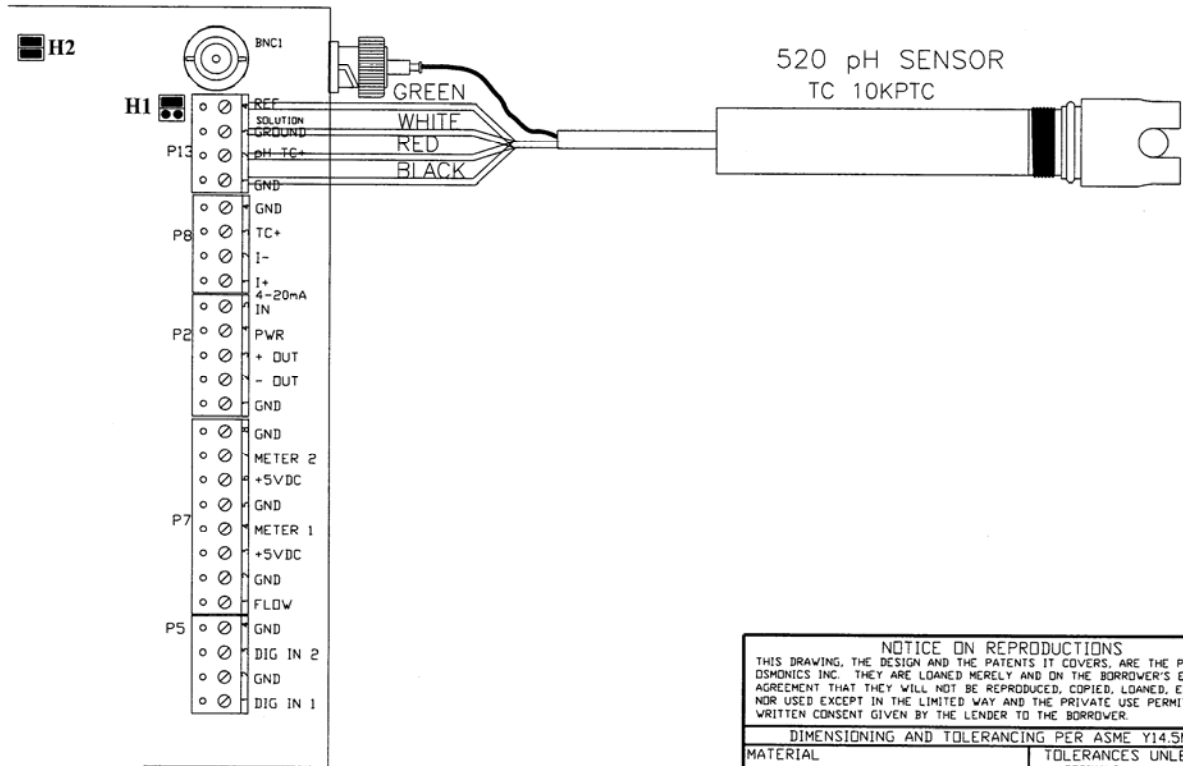

<p>NOTICE ON REPRODUCTIONS</p> <p>THIS DRAWING, THE DESIGN AND THE PATENTS IT COVERS, ARE THE PROPERTY OF OSMONICS INC. THEY ARE LOANED MERELY AND ON THE BORROWER'S EXPRESS AGREEMENT THAT THEY WILL NOT BE REPRODUCED, COPIED, LOANED, EXHIBITED, NOR USED EXCEPT IN THE LIMITED WAY AND THE PRIVATE USE PERMITTED BY WRITTEN CONSENT GIVEN BY THE LENDER TO THE BORROWER.</p>					
<p>DIMENSIONING AND TOLERANCING PER ASME Y14.5M-1994</p>				<p>TITLE</p> <p>520 SENSOR WIRING FOR THE 1520/30e</p>	
MATERIAL	N/A	<p>TOLERANCES UNLESS NOTED</p> <p>DECIMALS .X ±</p> <p>ANGLES ±</p> <p>SURFACE .XXX ±</p> <p>✓</p>		SIZE	B
FINISH	N/A	DWN	DGK	DATE	2/11/04
		CHKD	PEP	DATE	2/11/04
PROJECT:	N/A	APVD	LRS	DATE	2/11/04
LIBRARY:	N/A	PART VERSION		N/A	
		SCALE	NTS	SHEET	1 OF 1
		PN		1220993	REV A
		DWG NO		1207162	REV A

REVISION		REVISION HISTORY			
DWG	PART	DESCRIPTION	ECD	DWN/DATE	APVD/DATE
A	A	RELEASE	8452	DGK/2/11/04	LRS/2/11/04

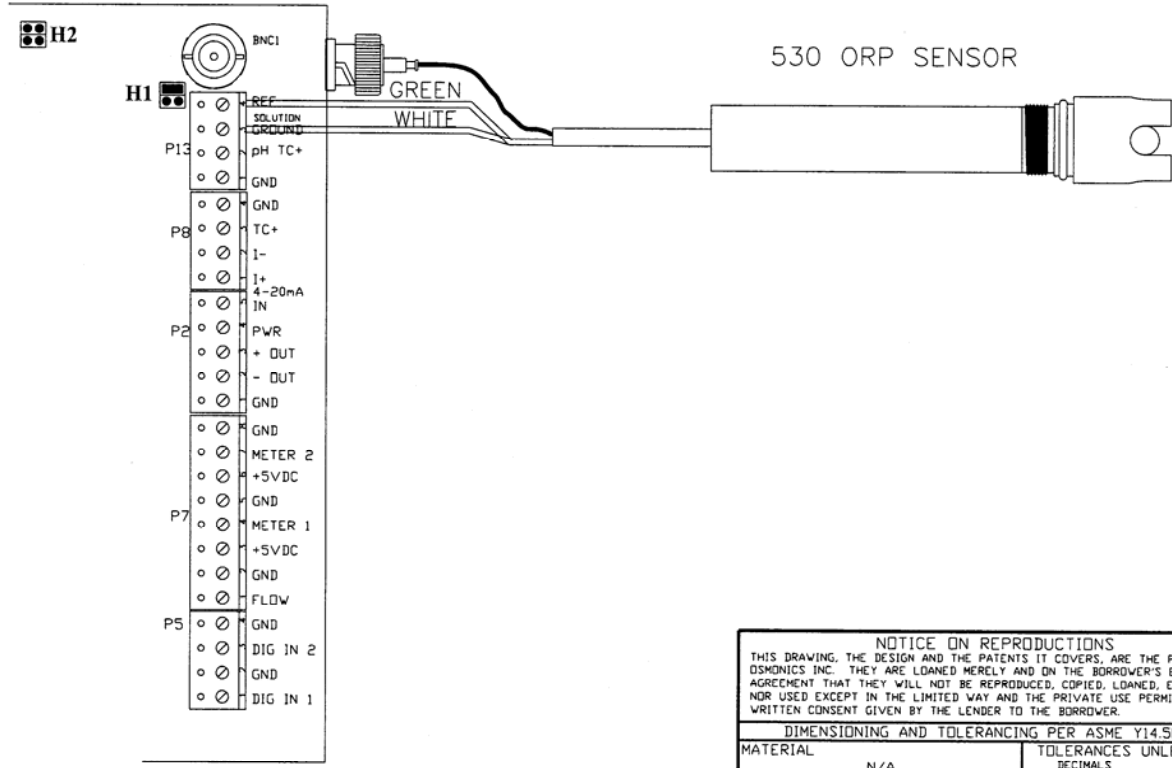

<p>NOTICE ON REPRODUCTIONS</p> <p>THIS DRAWING, THE DESIGN AND THE PATENTS IT COVERS, ARE THE PROPERTY OF OSMONICS INC. THEY ARE LOANED MERELY AND ON THE BORROWER'S EXPRESS AGREEMENT THAT THEY WILL NOT BE REPRODUCED, COPIED, LOANED, EXHIBITED, NOR USED EXCEPT IN THE LIMITED WAY AND THE PRIVATE USE PERMITTED BY WRITTEN CONSENT GIVEN BY THE LENDER TO THE BORROWER.</p>							
<p>DIMENSIONING AND TOLERANCING PER ASME Y14.5M-1994</p>				<p>TITLE</p> <p>530 SENSOR WIRING FOR THE 1520/30e</p>			
<p>MATERIAL</p> <p>N/A</p>	<p>TOLERANCES UNLESS NOTED</p> <p>DECIMALS</p> <p>.X ±</p> <p>.XX ±</p> <p>.XXX ±</p> <p>ANGLES</p> <p>±</p> <p>SURFACE</p> <p>✓</p>	<p>FINISH</p> <p>N/A</p>	<p>DWN</p> <p>CHKD</p> <p>APVD</p> <p>LIBRARY:</p>	<p>DATE</p> <p>DATE</p> <p>DATE</p> <p>PART VERSION</p>	<p>SIZE</p> <p>B</p> <p>SCALE</p> <p>NTS</p>	<p>PN</p> <p>1220993</p> <p>DWG NO</p> <p>1207164</p>	<p>REV</p> <p>A</p> <p>REV</p> <p>A</p>
<p>PROJECT: N/A</p>		<p>APVD LRS</p>		<p>SHEET</p> <p>1 OF 1</p>		<p>DATE</p> <p>2/11/04</p>	

REVISION		REVISION HISTORY			
DWG	PART	DESCRIPTION	ECO	DWN/DATE	APVD/DATE
A	A				

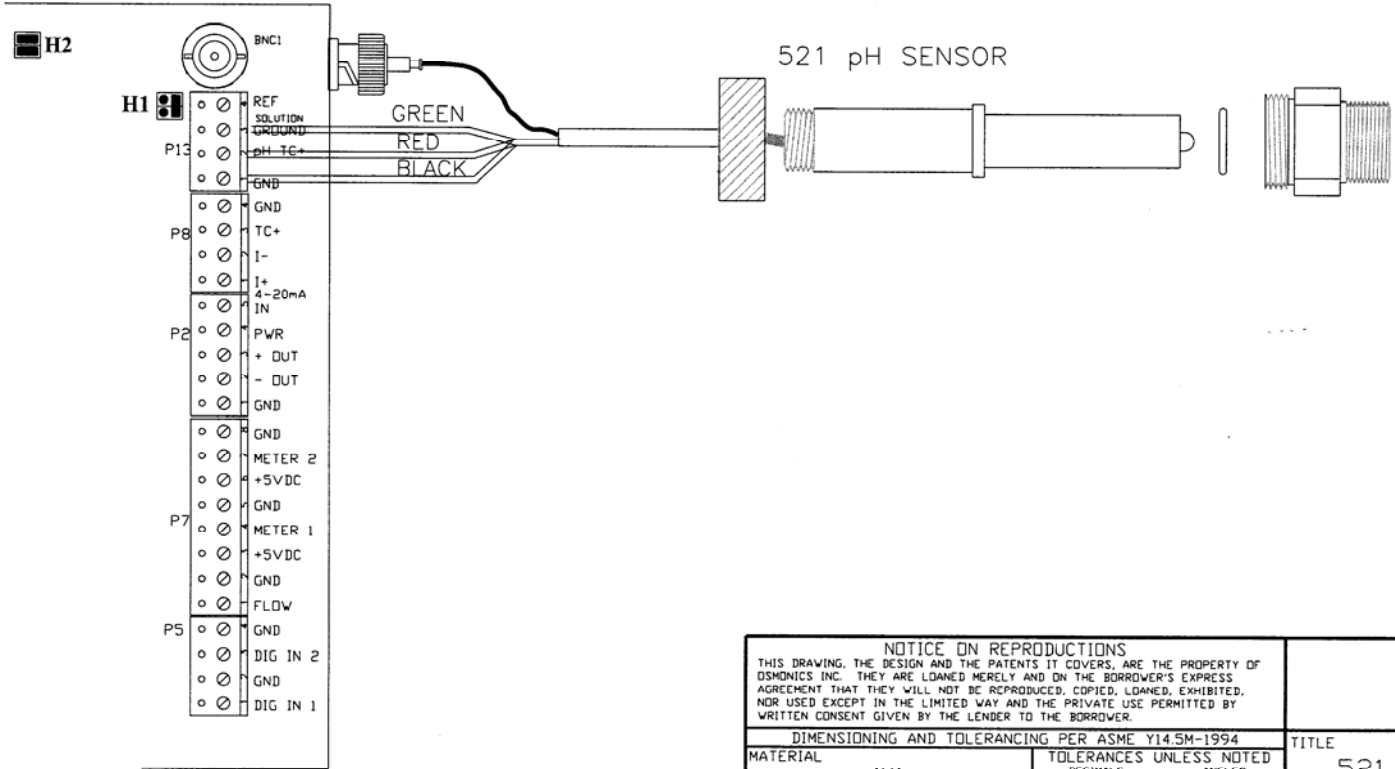

<p>NOTICE ON REPRODUCTIONS THIS DRAWING, THE DESIGN AND THE PATENTS IT COVERS, ARE THE PROPERTY OF OSMONICS INC. THEY ARE LOANED MERELY AND ON THE BORROWER'S EXPRESS AGREEMENT THAT THEY WILL NOT BE REPRODUCED, COPIED, LOANED, EXHIBITED, NOR USED EXCEPT IN THE LIMITED WAY AND THE PRIVATE USE PERMITTED BY WRITTEN CONSENT GIVEN BY THE LENDER TO THE BORROWER.</p>					
<p>DIMENSIONING AND TOLERANCING PER ASME Y14.5M-1994</p>				<p>TITLE 521 SENSOR WIRING FOR THE 1520/30e</p>	
MATERIAL	N/A	<p>TOLERANCES UNLESS NOTED</p> <p>DECIMALS .X ± .XX ± .XXX ±</p> <p>ANGLES ± SURFACE ✓</p>		SIZE	B
FINISH	N/A	DWN	DGK	DATE	PN
		CHKD		DATE	1220993
PROJECT:	N/A	APVD		DATE	REV A
LIBRARY:	N/A	PART VERSION	N/A	SCALE	NTS
				SHEET	1 OF 1
				DWG NO	1207163
				REV	A

NOTES: UNLESS OTHERWISE SPECIFIED;
 ⚠ FOR INTERNAL 24VDC JUMPER WIRE IS REQUIRED.

REVISION		REVISION HISTORY			
DWG	PART	DESCRIPTION	ECD	DWN/DATE	APVD/DATE
A	A	RELEASE	8452	DGK/2/11/04	LRS/2/11/04

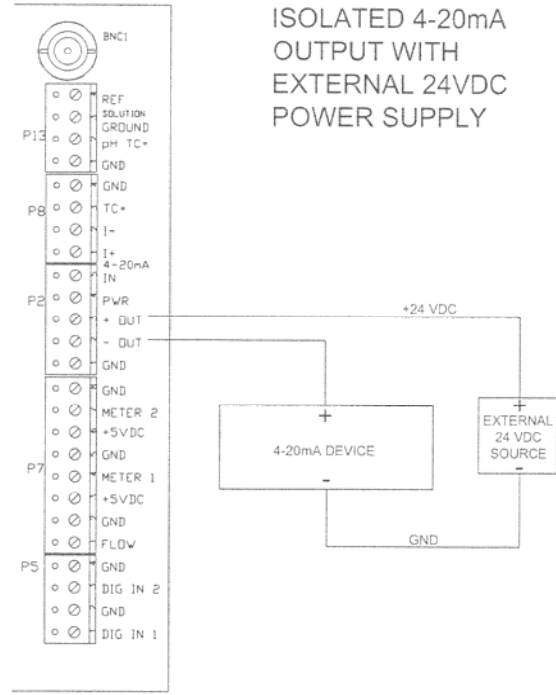
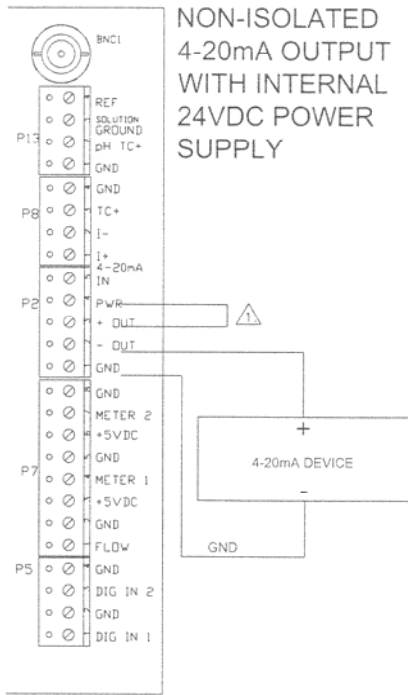
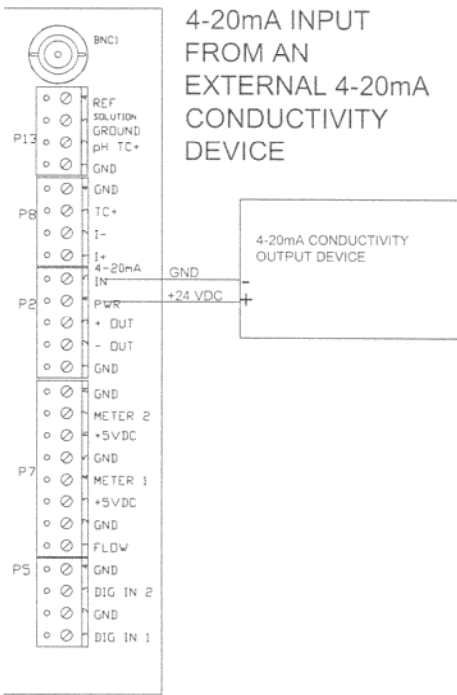

NOTICE ON REPRODUCTIONS
 THIS DRAWING, THE DESIGN AND THE PATENTS IT COVERS, ARE THE PROPERTY OF OSMONICS INC. THEY ARE LOANED MERELY AND ON THE BORROWER'S EXPRESS AGREEMENT THAT THEY WILL NOT BE REPRODUCED, COPIED, LOANED, EXHIBITED, NOR USED EXCEPT IN THE LIMITED WAY AND THE PRIVATE USE PERMITTED BY WRITTEN CONSENT GIVEN BY THE LENDER TO THE BORROWER.

DIMENSIONING AND TOLERANCING PER ASME Y14.5M-1994

MATERIAL	N/A	TOLERANCES UNLESS NOTED	
		DECIMALS	ANGLES
		.X ±	±
		.XX ±	SURFACE
		.XXX ±	

FINISH	N/A	DWN	DGK	DATE	2/11/04
		CHKD	PEP	DATE	2/11/04
PROJECT:	N/A	APVD	LRS	DATE	2/11/04
LIBRARY:	N/A	PART VERSION	N/A		



TITLE		4-20mA WIRING FOR THE 1520/30e			
SIZE	B	PN	1220993	REV	A
SCALE	NTS	SHEET	1 OF 1	DWG NO	1207161

For more information call toll free in the USA (800) 228-0839

Manufactured in the USA

Lakewood Instruments

7838 North Faulkner Road, Milwaukee, WI 53224 USA

Phone (800) 228-0839 • Fax (414) 355-3508

<http://www.lakewoodinstruments.com>